

Gen. 8:21 **Curse** **Buster**TM Luke 17:37b

December 2, 2014

Dear Friends and Supporters,

We want to first of all express our thanks to you for your prayerful encouragement during this past year and in the past. Without you and the Grace of God that is ministered through you we would have surely fainted in the way. As it is we have continued on our course to the present situation which is far better than we had ever expected even a few months ago. This includes our new to us home, office and shop location at 4107 East 1050 North in Ossian, IN 46777; Still known as the Dettmer Homestead and home of Provision Farm.

We have had our bumps along the path and tried our best to remedy each one as quickly as we could. If you have unresolved problems we want to know about them. Sometimes we have had no control over such things as a poor job of machining or a fastener that wasn't the alloy it was supposed to be. We have sincerely appreciated your patience and kind support with the use of your personnel, shops, welders, impact tools, forklifts and loaders as we have endeavored to get you back in the field and keep you there till the job is done.

We are continually affirmed in our convictions by your testimonies that the form of the tillage that the Curse Buster brings to our farmland is indeed a blessing from the Lord. To experience the fullness of the blessing, faithful execution over time and a different skill set that is not the norm is required. Just one example of this occurred recently when I was reminded, in a pointed way, that I needed to continue to emphasize the importance of taking soil samples at no more than 3 inches in depth for keeping a handle on the soils increasing need for calcium supplementation.

Then on a recent trip to Northern NY I was privileged to talk briefly with Todd Mason who has this year completed 30 years of very strict adherence to the vertical tillage practice which Curse Buster has faithfully continued in the tradition of the New Zealand original Ground-Hog which Todd is still using. Todd informed me that he finished 3rd place with 30 tons/acre in a nationwide Golden Harvest corn silage yield competition. He did nothing more than the usual manuring and 2X single rank tillage pass with his original Aerway frame which has been running with retrofitted Smart-Till tines. These soils also are decomposing glyphosate and AMPA (a metabolite of glyphosate) at record rates of less than 30 days for a one quart rate and continuing to supply superior nutrition to the plants they feed to their dairy herd.

Sure, I am encouraging myself a bit here. I need to once in awhile just like everybody else. The conclusion of it all is that we have a plan to make a still better machine for 2015 than we have built so far. If you are one of those that have been sitting on the fence about the decision to

Curse Gen. 8:21 Buster Luke 17:37b TM

December 2, 2014

move into the next level from Gen-Till, Aerway, no-till or strip-till, we want to encourage you to get onboard before December gets by us. Son Daniel informs me that the doors for an early March 2015 delivery date will close on December 15th. We currently have one machine deposit in place and three more that are getting finances arranged. Please don't put us and yourselves under the gun by delaying the decision. We have leasing opportunities too with John Deere Credit and Accord Leasing if that is of interest.

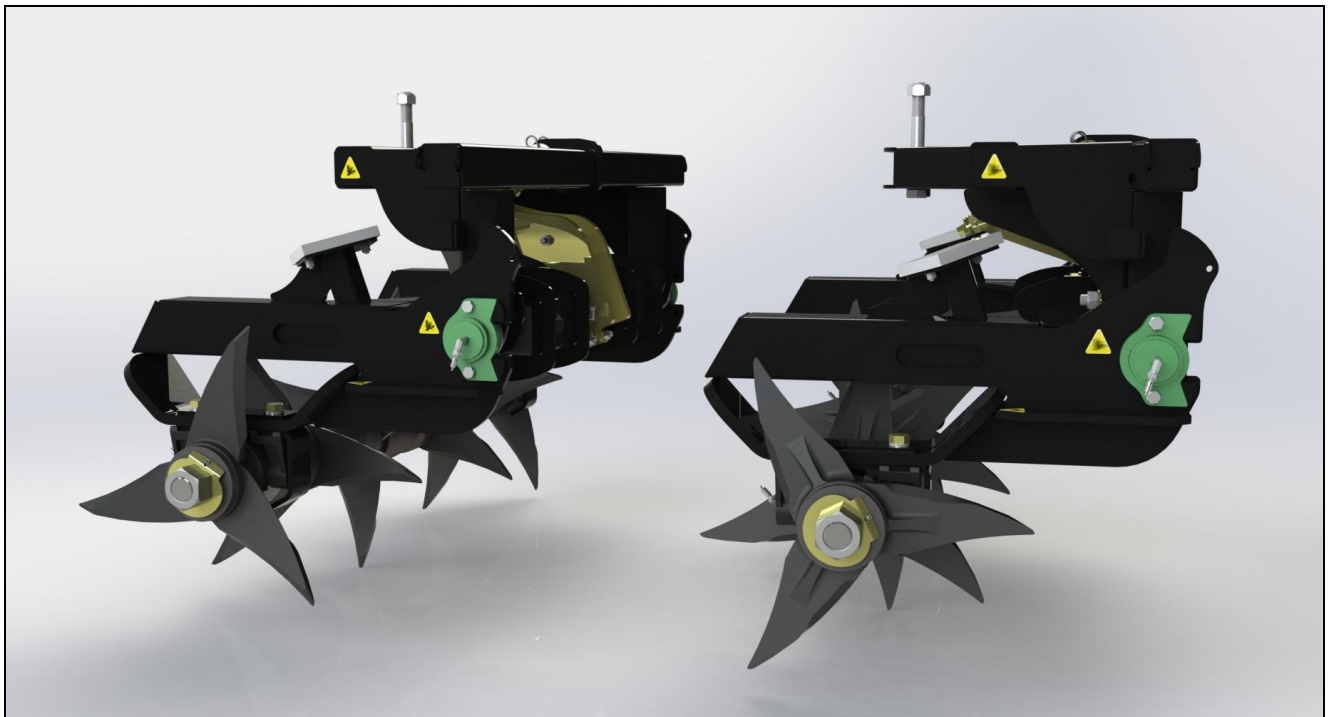

This is a sneak preview of the latest modification to the patent pending suspension system. We have six of these types of rubber torsion systems running since April of 2014. This new orientation with both front and rear roller assemblies on trialing arms we believe will address the only problem we experienced with the first six units. Frankly we did not anticipate how far down the front unit would drop into some of the drainages in your fields.

We also thought it advisable to shield over the rollers to prevent possible injury. This feature created some trash clearing issues at the rear of the rollers. That feature is gone now for two reasons.

Curse Gen. 8:21 Buster™ Luke 17:37b

December 2, 2014

First of all to adjust the roller offset is now done with both feet on the ground instead of both feet off the ground. Secondly, the front roller rear discharge is unobstructed. So let's take a look at the new adjusting system. It is now capable of adjusting back to the zero offset position and resetting to the selected angle of roller offset while underway.

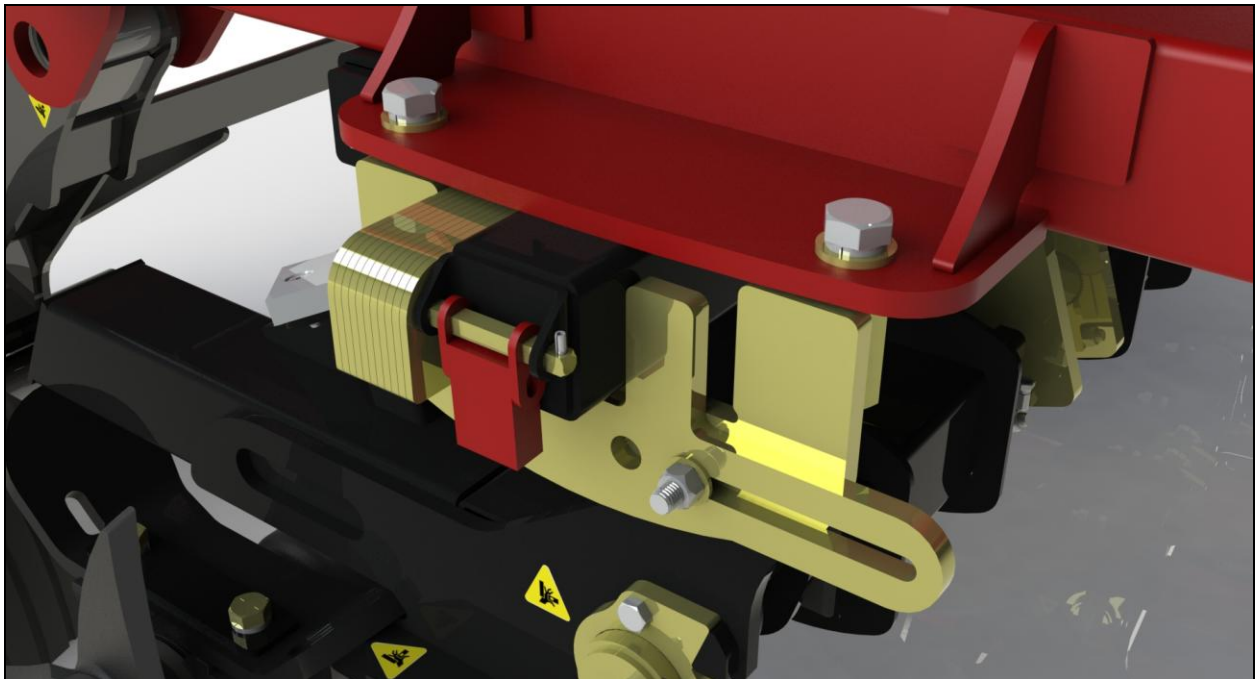

This setting is at zero degrees of roller offset. To increase the offset angle the number of plates sandwiched on the square pin is reduced. Once removed the turnbuckle or optional hydraulic cylinder is extended to fasten the roller swingarm firmly against the remaining plates.

Relocation of the adjustable stop bar (which has the adjusting slot pictured here) is done to assure that the roller swap from rear to front and vice versa will always guarantee the operator is offsetting the roller in the correct direction.

The shimming plates allow the roller assembly to be adjustable in ½ degree increments.

December 2, 2014

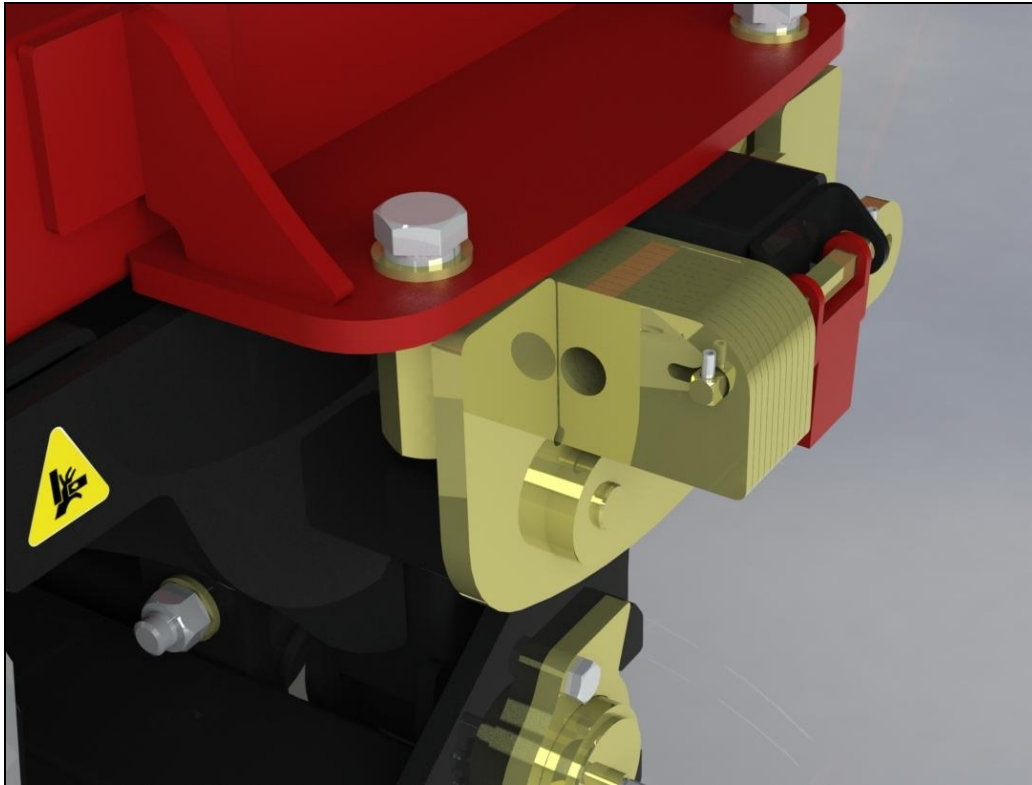

Other improvements have been made to the harrow system. This link to [DROPBOX](#) will show me effortlessly turning harrows 180 degrees from passive to aggressive tine action. NOT shown in the video is the latest advance which reduces the number of nuts that have to be removed to make this adjustment. Instead of using 8 capscrews we now use 2 U-Bolts.

Another addition for folks who choose manual adjustment of the rotary harrow working angle, they now have two pin locations which fix the harrows in the center position for transport.

[Click here](#) to watch harrows reversing on a 30 foot machine.

[THIS LINK](#) will show you all the hydraulically controlled movements of The Phillips harrows on a 15 foot machine. If you need to avoid rocks or burr cucumber or bindweed vines just raise them up. If you want to incorporate seed, fertilizer or lime or just move soil and residue in the same direction across the field surface, this is what you need.

Please pray for us all as we endeavor to honor our Lord and Savior, Jesus Christ, in our lives. Thanks and may the Lord Jesus bless you and yours.

Jim, Dan and Christian for all the Martindales