

ITEM NO.	PartNo	QTY.	Weight	Description	Material	Length
1	2011012C0	3	2.49	ROLLER HARTING RING DRIVER	80-55-06	
2	2011018C1	6	2.37	Harting Ring, Cast	80-55-06	
3	2011057C0	9	4.883	CCW Tine, Tabs Base, hard-faced	2011013C2	
4	2011074C1	2	20.96	Short Spacer, Cast	65-45-12	
5	2011085C0	4	3.50	End Cap	80-55-06	
6	2011087C1	1	20.22	Bearings are set on the turned outer ends of the shaft inboard of the threads.	BAR HEX-1.75, 4140	27.625
7	2011185P0	2	1.60	1-3/4"-12 Grade 8 Hex Nut, MCM# 90499A868	Grade 8 Steel	
8	2012180C1	2	3.49	End Cap, drilled	2011085C0	
9	2012182C1	2	0.27	Roller nut lock flange	SH-14GA	2
10	2012184P1	2	0.008	1/4" x 1" Zinc-Plated Steel Slotted Spring Pin, MCM# 90692A742	MCM# 90692A742	
11	2014183P0	4	0.13	Flat roller bearing washer, BOKERS# 422395	BOKERS# 422395	0.125
12	ASM986A04	2	9.23	Roller Bearing Unit		

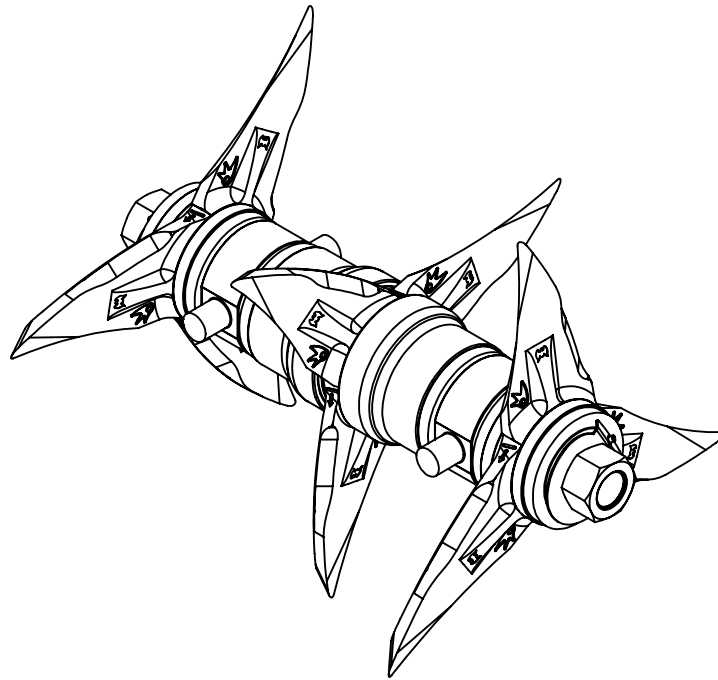

Assembly BOM Link: [ASM988A03.xls](#)
 (contains prints to constituent part prints)

Drawing Name: ASM988A03		REVISION 0	PART NO. ASM988A03		DESCRIPTION: 3star Roller, CCW
A:		DATE 3/28/2016	PROCESSES		WEIGHT: 30.44Lbs
B:		DEBUR AND BREAK SHARP EDGES	Assemble		Soil Regeneration Unlimited
C:		UNLESS OTHERWISE SPECIFIED: DIMENSIONS ARE IN INCHES SURFACE FINISH: TOLERANCES: LINEAR: 1/16" ANGULAR: 2°	Grease		
D:		DO NOT SCALE DRAWING			PROPRIETARY AND CONFIDENTIAL
E:		A4	SCALE: 1:8		THE INFORMATION CONTAINED IN THIS DRAWING IS THE SOLE PROPERTY OF SOIL REGENERATION UNLIMITED. ANY REPRODUCTION IN PART OR AS A WHOLE WITHOUT THE WRITTEN PERMISSION OF SOIL REGENERATION UNLIMITED IS PROHIBITED.
NAME Daniel R. M.	SIGNATURE	SHEET 1 OF 13			

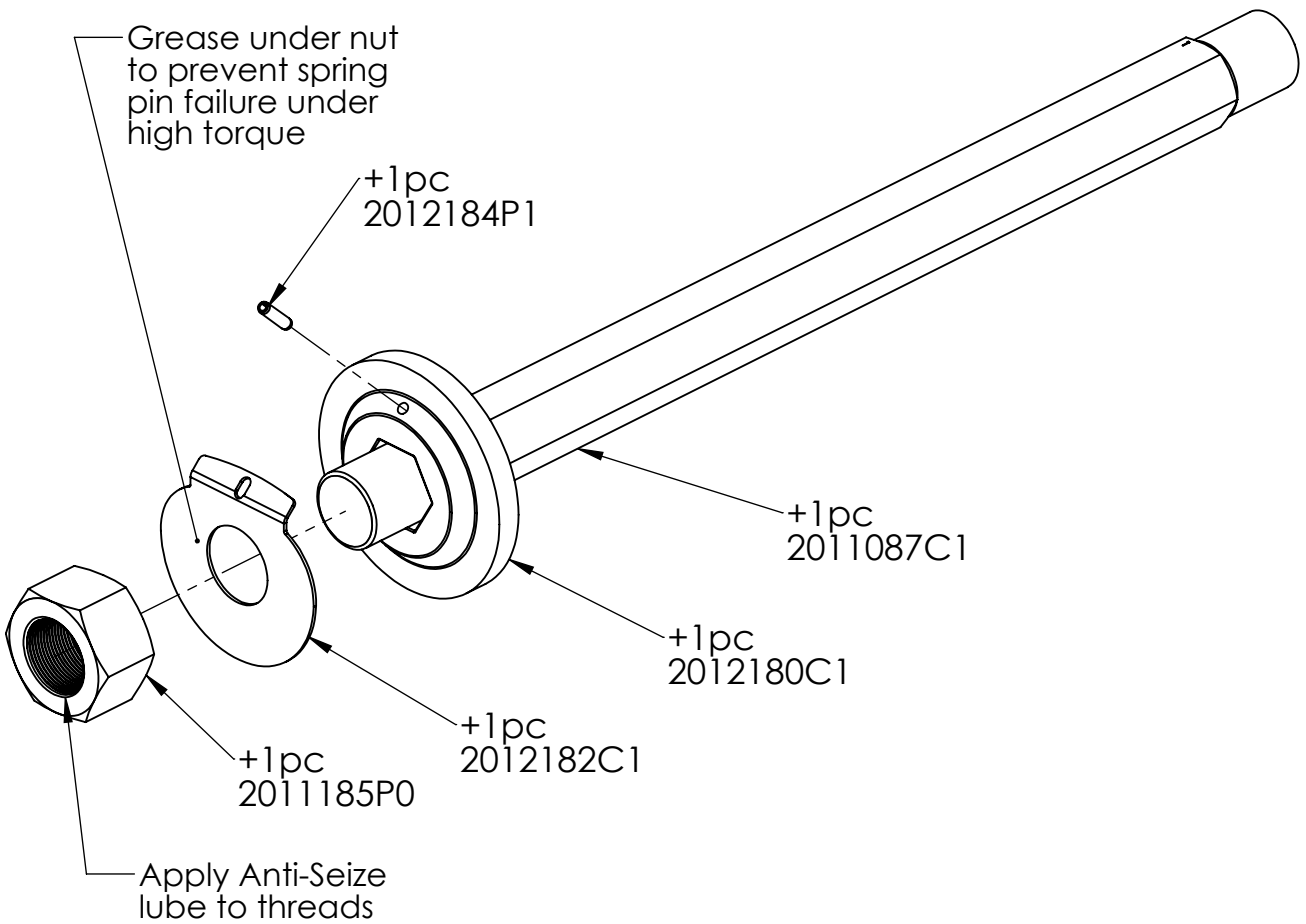
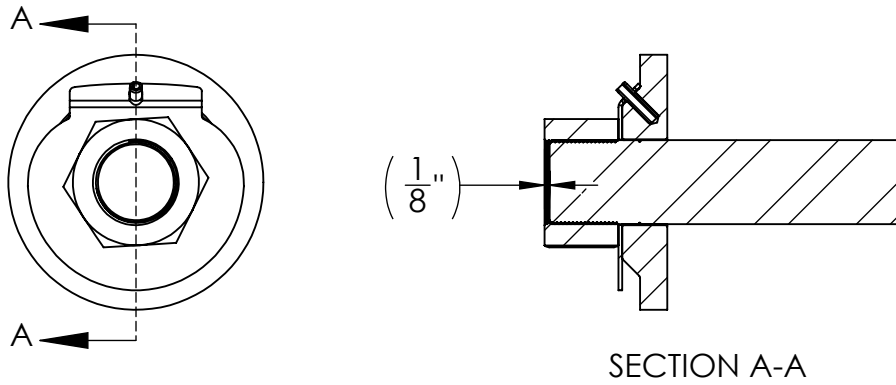

Drawing Name: ASM988A03		REVISION 0 DATE 3/28/2016	Assembly BOM Link: (contains prints to constituent part prints) ASM988A03.xls		PART NO. ASM988A03	DESCRIPTION: 3star Roller, CCW
A:			DEBUR AND BREAK SHARP EDGES		PROCESSES	WEIGHT: 30.44Lbs
B:			UNLESS OTHERWISE SPECIFIED: DIMENSIONS ARE IN INCHES SURFACE FINISH: TOLERANCES: LINEAR: 1/16" ANGULAR: 2°		Assemble	Soil Regeneration Unlimited
C:			DO NOT SCALE DRAWING		Grease	
D:			A4		SCALE: 1:4	PROPRIETARY AND CONFIDENTIAL
E:			SHEET 2 OF 13		THE INFORMATION CONTAINED IN THIS DRAWING IS THE SOLE PROPERTY OF SOIL REGENERATION UNLIMITED. ANY REPRODUCTION IN PART OR AS A WHOLE WITHOUT THE WRITTEN PERMISSION OF SOIL REGENERATION UNLIMITED IS PROHIBITED.	
NAME Daniel R. M.	SIGNATURE					

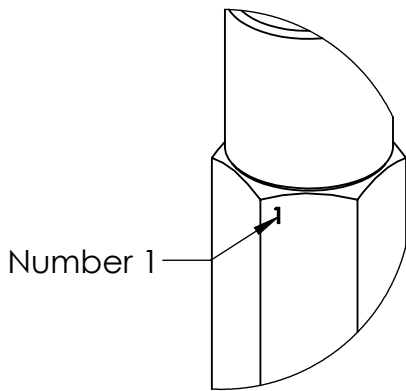

Number 1

DETAIL C
SCALE 1 : 2

Ridge aligned
with spline
numbered 1

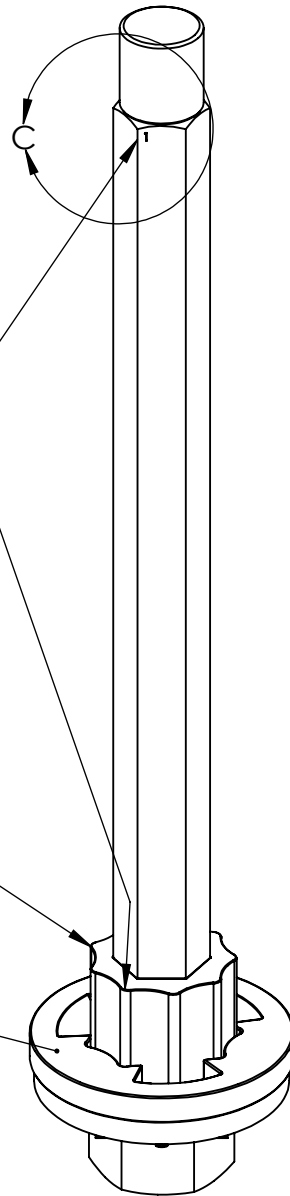

+1pc
2011012C0

+1pc
2011018C1

Assembly BOM Link: [ASM988A03.xls](#)
(contains prints to constituent part prints)

Drawing Name: ASM988A03		REVISION 0 DATE 3/28/2016	PART NO. ASM988A03	DESCRIPTION: 3star Roller, CCW
A:		DEBUR AND BREAK SHARP EDGES UNLESS OTHERWISE SPECIFIED: DIMENSIONS ARE IN INCHES SURFACE FINISH: TOLERANCES: LINEAR: 1/16" ANGULAR: 2° DO NOT SCALE DRAWING	PROCESSES	WEIGHT: 30.44Lbs
B:			Assemble	Soil Regeneration Unlimited
C:			Grease	
D:				PROPRIETARY AND CONFIDENTIAL
E:				THE INFORMATION CONTAINED IN THIS DRAWING IS THE SOLE PROPERTY OF SOIL REGENERATION UNLIMITED. ANY REPRODUCTION IN PART OR AS A WHOLE WITHOUT THE WRITTEN PERMISSION OF SOIL REGENERATION UNLIMITED IS PROHIBITED.
NAME Daniel R. M.	SIGNATURE	A4 SCALE: 1:4	SHEET 3 OF 13	

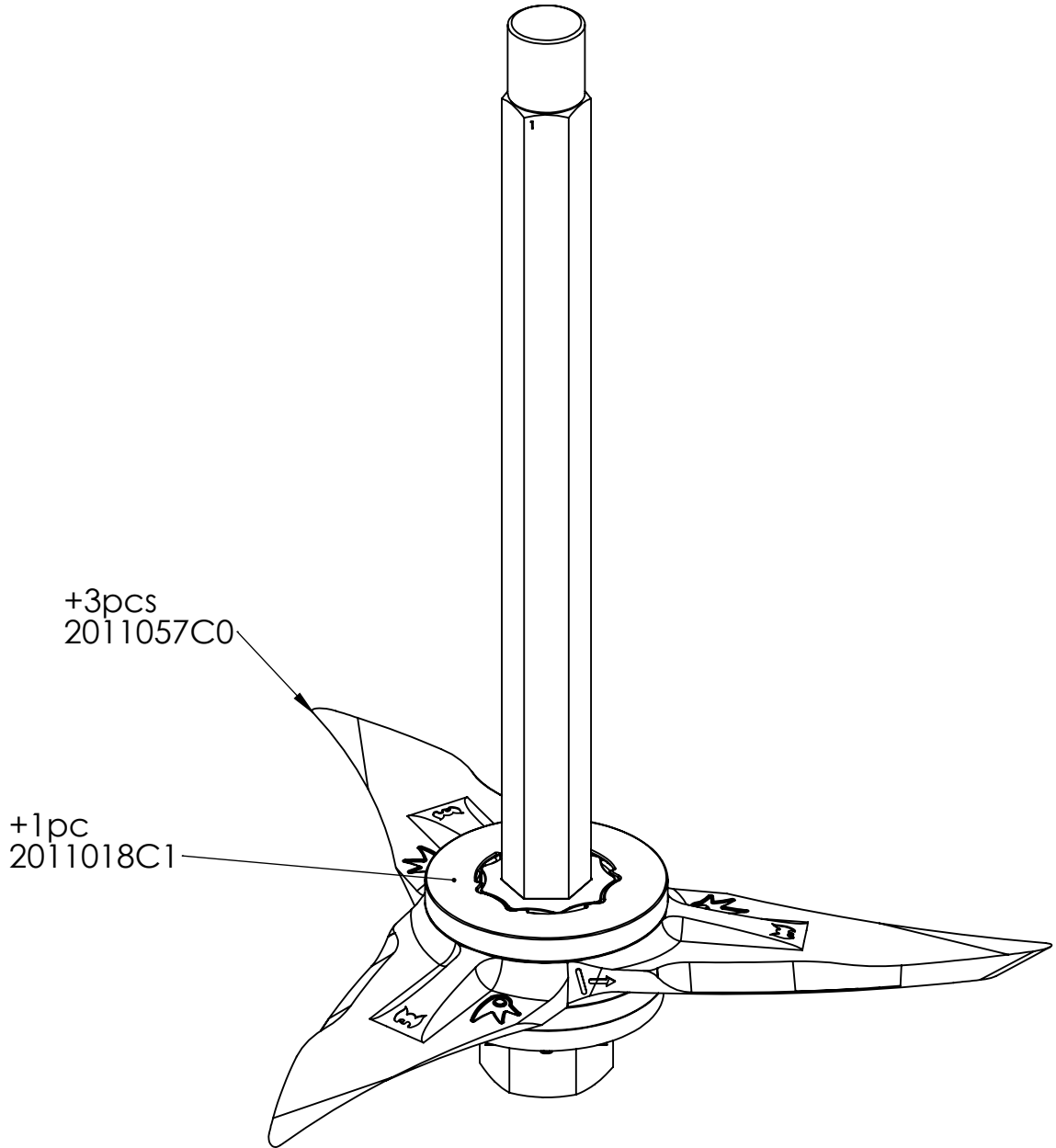

Assembly BOM Link: [ASM988A03.xls](#)
 (contains prints to constituent part prints)

Drawing Name: ASM988A03		REVISION 0	PART NO. ASM988A03		DESCRIPTION: 3star Roller, CCW
A:		DATE 3/28/2016	PROCESSES		WEIGHT: 30.44Lbs
B:		DEBUR AND BREAK SHARP EDGES UNLESS OTHERWISE SPECIFIED: DIMENSIONS ARE IN INCHES SURFACE FINISH: TOLERANCES: LINEAR: 1/16" ANGULAR: 2°	Assemble		Soil Regeneration Unlimited
C:			Grease		
D:			DO NOT SCALE DRAWING		PROPRIETARY AND CONFIDENTIAL THE INFORMATION CONTAINED IN THIS DRAWING IS THE SOLE PROPERTY OF SOIL REGENERATION UNLIMITED. ANY REPRODUCTION IN PART OR AS A WHOLE WITHOUT THE WRITTEN PERMISSION OF SOIL REGENERATION UNLIMITED IS PROHIBITED.
E:			A4 SCALE: 1:4		
NAME Daniel R. M.	SIGNATURE	SHEET 4 OF 13			

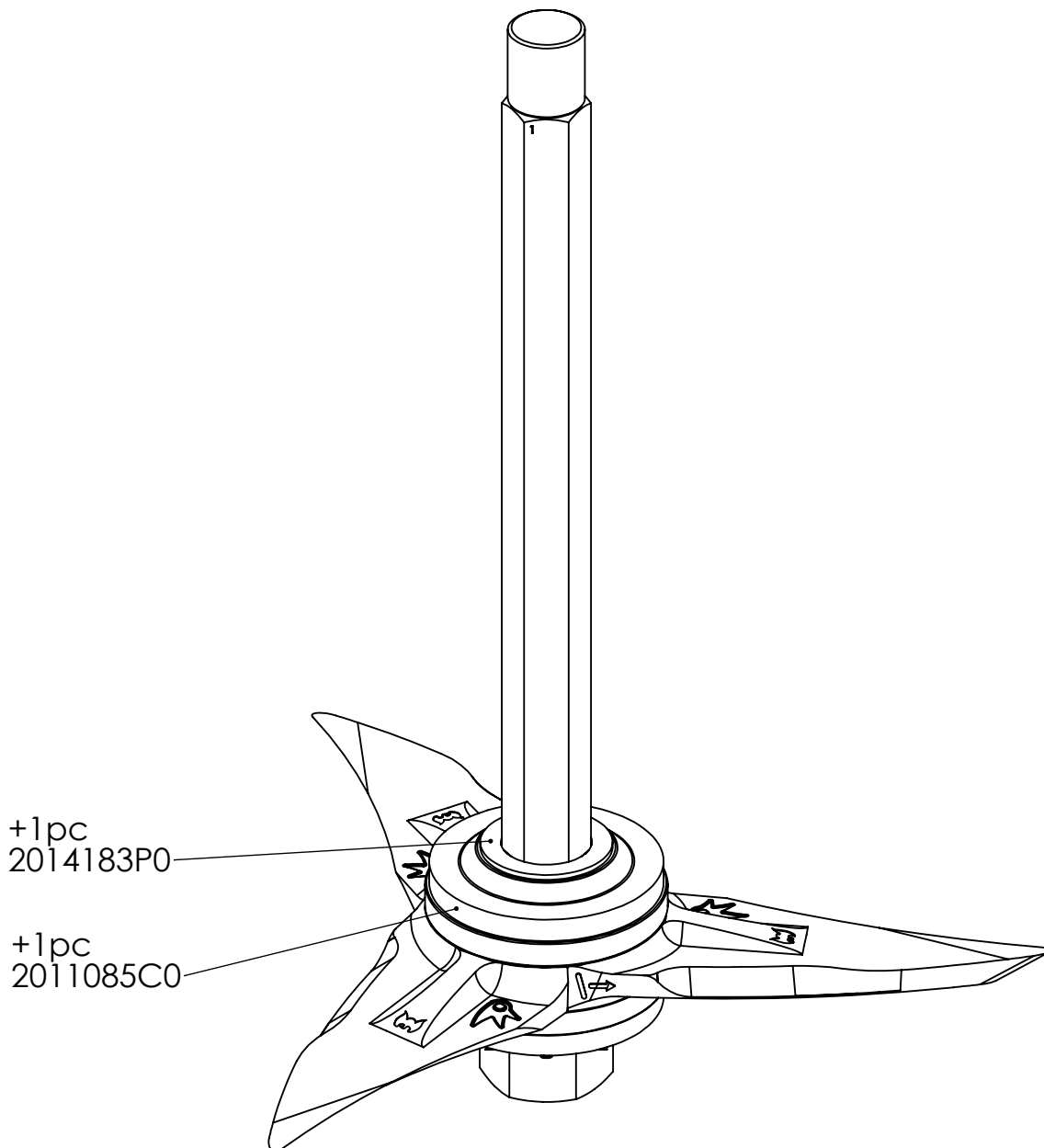

Assembly BOM Link: [ASM988A03.xls](#)
 (contains prints to constituent part prints)

Drawing Name: ASM988A03		REVISION 0	PART NO. ASM988A03		DESCRIPTION: 3star Roller, CCW
A:		DATE 3/28/2016	PROCESSES		WEIGHT: 30.44Lbs
B:		DEBUR AND BREAK SHARP EDGES UNLESS OTHERWISE SPECIFIED: DIMENSIONS ARE IN INCHES SURFACE FINISH: TOLERANCES: LINEAR: 1/16" ANGULAR: 2°	Assemble		
C:			Grease		
D:			DO NOT SCALE DRAWING		
E:			A4 SCALE: 1:4		
NAME Daniel R. M.	SIGNATURE	SHEET 5 OF 13		PROPRIETARY AND CONFIDENTIAL THE INFORMATION CONTAINED IN THIS DRAWING IS THE SOLE PROPERTY OF SOIL REGENERATION UNLIMITED. ANY REPRODUCTION IN PART OR AS A WHOLE WITHOUT THE WRITTEN PERMISSION OF SOIL REGENERATION UNLIMITED IS PROHIBITED.	

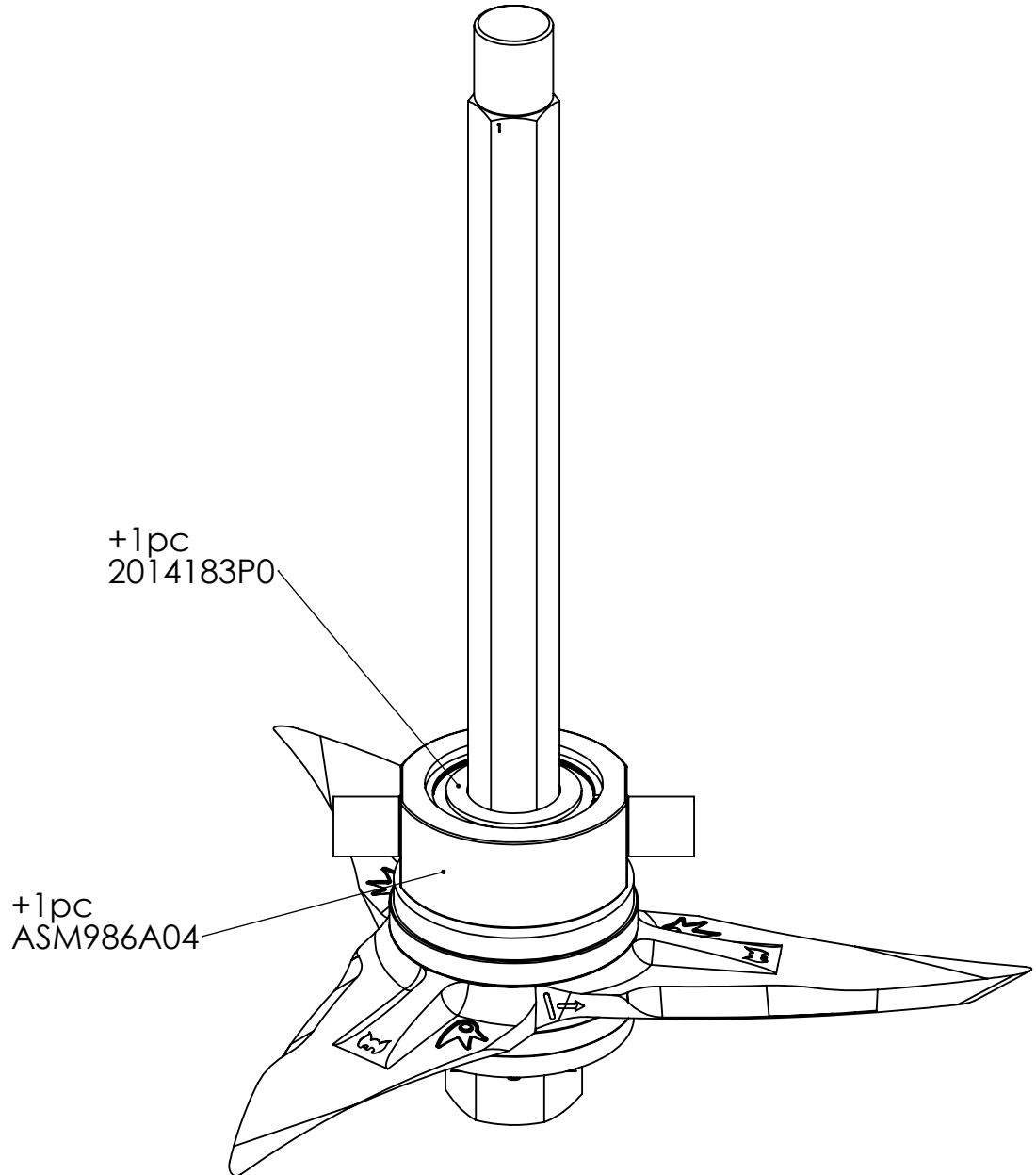

Assembly BOM Link: [ASM988A03.xls](#)
 (contains prints to constituent part prints)

Drawing Name: ASM988A03		REVISION 0	PART NO. ASM988A03		DESCRIPTION: 3star Roller, CCW
A:		DATE 3/28/2016	PROCESSES		WEIGHT: 30.44Lbs
B:		DEBUR AND BREAK SHARP EDGES UNLESS OTHERWISE SPECIFIED: DIMENSIONS ARE IN INCHES SURFACE FINISH: TOLERANCES: LINEAR: 1/16" ANGULAR: 2°	Assemble		Soil Regeneration Unlimited
C:			Grease		
D:			DO NOT SCALE DRAWING		PROPRIETARY AND CONFIDENTIAL THE INFORMATION CONTAINED IN THIS DRAWING IS THE SOLE PROPERTY OF SOIL REGENERATION UNLIMITED. ANY REPRODUCTION IN PART OR AS A WHOLE WITHOUT THE WRITTEN PERMISSION OF SOIL REGENERATION UNLIMITED IS PROHIBITED.
E:			A4 SCALE: 1:4		
NAME Daniel R. M.	SIGNATURE	SHEET 6 OF 13			

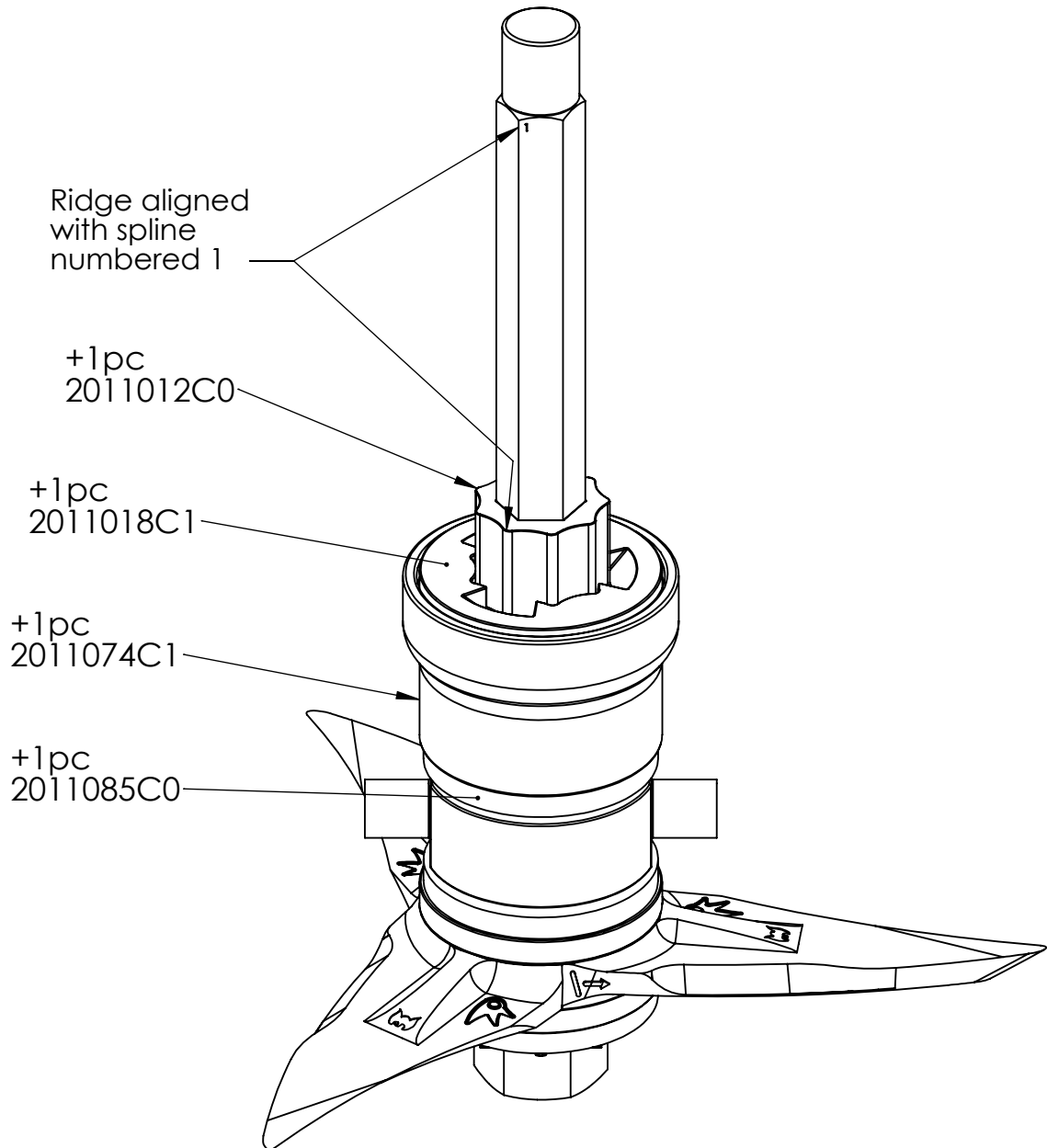

Assembly BOM Link: [ASM988A03.xls](#)
 (contains prints to constituent part prints)

Drawing Name: ASM988A03		REVISION 0	PART NO. ASM988A03		DESCRIPTION: 3star Roller, CCW
A:		DATE 3/28/2016	PROCESSES		WEIGHT: 30.44Lbs
B:		DEBUR AND BREAK SHARP EDGES UNLESS OTHERWISE SPECIFIED: DIMENSIONS ARE IN INCHES SURFACE FINISH: TOLERANCES: LINEAR: 1/16" ANGULAR: 2°	Assemble		Soil Regeneration Unlimited
C:			Grease		
D:			DO NOT SCALE DRAWING		PROPRIETARY AND CONFIDENTIAL THE INFORMATION CONTAINED IN THIS DRAWING IS THE SOLE PROPERTY OF SOIL REGENERATION UNLIMITED. ANY REPRODUCTION IN PART OR AS A WHOLE WITHOUT THE WRITTEN PERMISSION OF SOIL REGENERATION UNLIMITED IS PROHIBITED.
E:			A4 SCALE: 1:4		
NAME Daniel R. M.	SIGNATURE	SHEET 7 OF 13			

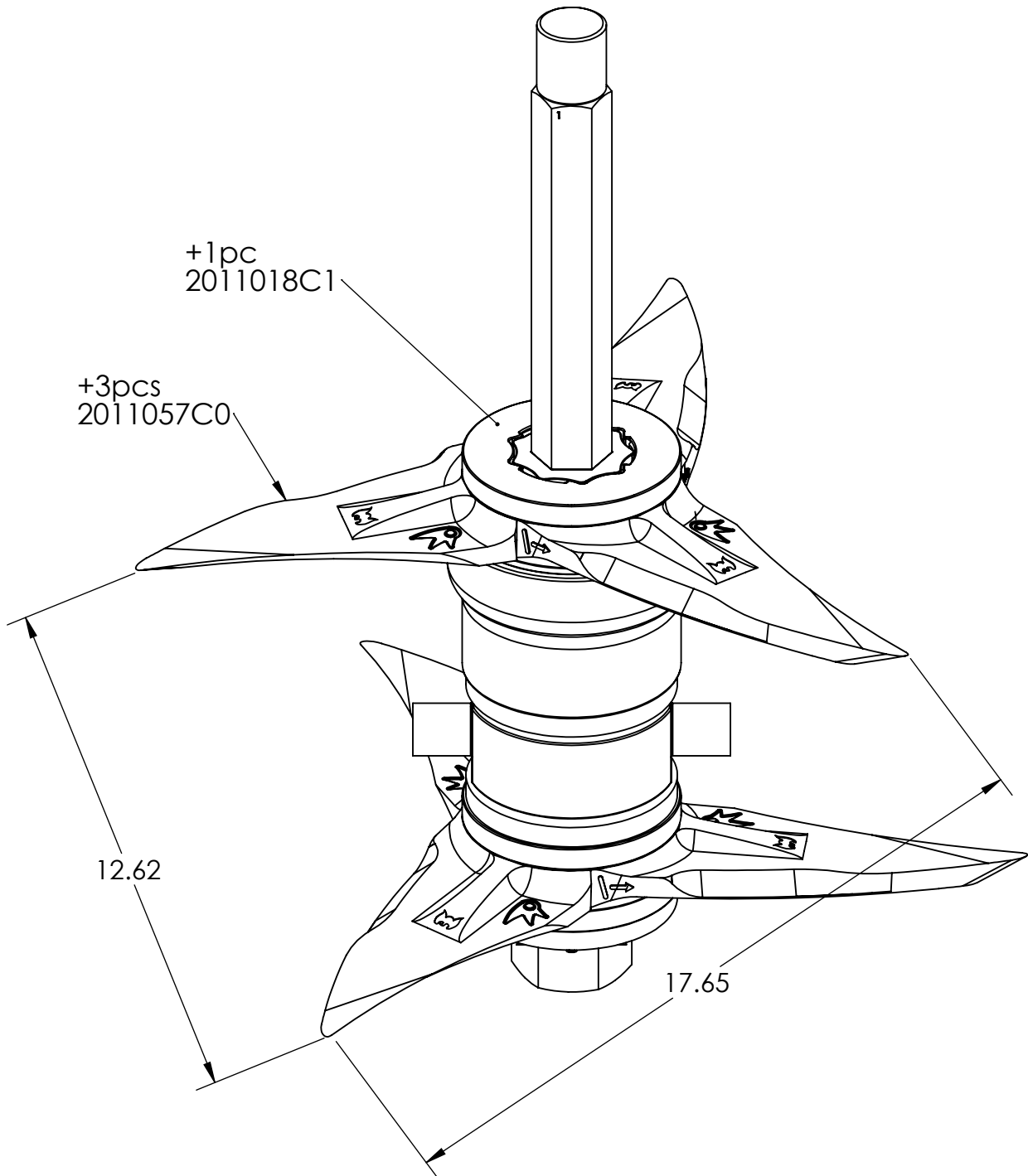

Assembly BOM Link: [ASM988A03.xls](#)
 (contains prints to constituent part prints)

Drawing Name: ASM988A03		REVISION 0 DATE 3/28/2016	
A:			
B:		DEBUR AND BREAK SHARP EDGES	
C:		UNLESS OTHERWISE SPECIFIED: DIMENSIONS ARE IN INCHES SURFACE FINISH: TOLERANCES: LINEAR: 1/16" ANGULAR: 2°	
D:			
E:		DO NOT SCALE DRAWING	
NAME Daniel R. M.		SIGNATURE	
		A4	SCALE: 1:4
		SHEET 8 OF 13	

PART NO. ASM988A03
PROCESSES
Assemble
Grease

DESCRIPTION: 3star Roller, CCW
WEIGHT: 30.44Lbs
Soil Regeneration Unlimited
PROPRIETARY AND CONFIDENTIAL THE INFORMATION CONTAINED IN THIS DRAWING IS THE SOLE PROPERTY OF SOIL REGENERATION UNLIMITED. ANY REPRODUCTION IN PART OR AS A WHOLE WITHOUT THE WRITTEN PERMISSION OF SOIL REGENERATION UNLIMITED IS PROHIBITED.

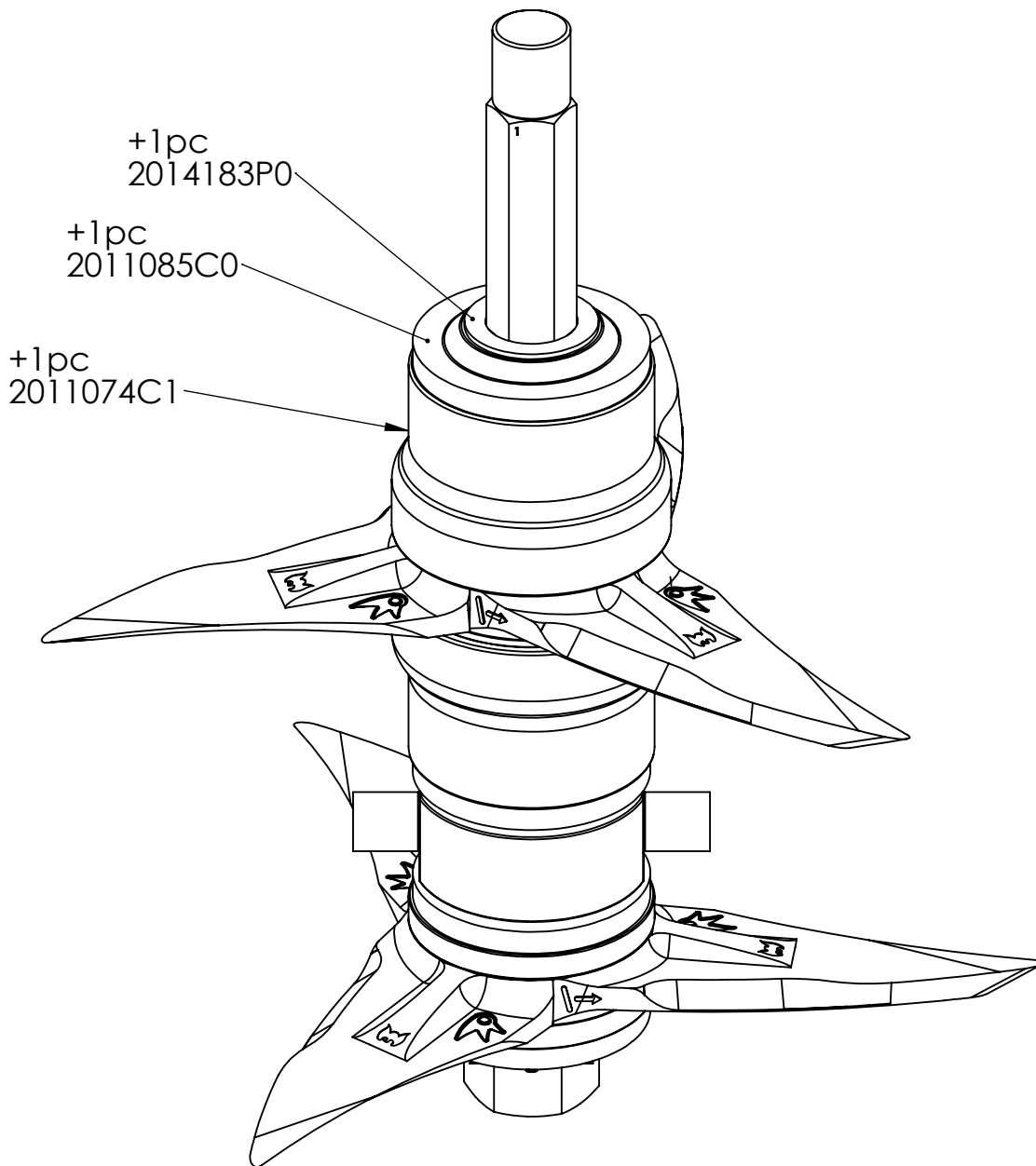

Assembly BOM Link: [ASM988A03.xls](#)
 (contains prints to constituent part prints)

Drawing Name: ASM988A03		REVISION 0 DATE 3/28/2016	PART NO. ASM988A03	DESCRIPTION: 3star Roller, CCW
A:		DEBUR AND BREAK SHARP EDGES UNLESS OTHERWISE SPECIFIED: DIMENSIONS ARE IN INCHES SURFACE FINISH: TOLERANCES: LINEAR: 1/16" ANGULAR: 2°	PROCESSES	WEIGHT: 30.44Lbs
B:			Assemble	Soil Regeneration Unlimited
C:			Grease	
D:				PROPRIETARY AND CONFIDENTIAL
E:				THE INFORMATION CONTAINED IN THIS DRAWING IS THE SOLE PROPERTY OF SOIL REGENERATION UNLIMITED. ANY REPRODUCTION IN PART OR AS A WHOLE WITHOUT THE WRITTEN PERMISSION OF SOIL REGENERATION UNLIMITED IS PROHIBITED.
NAME Daniel R. M.	SIGNATURE	DO NOT SCALE DRAWING A4 SCALE: 1:4	SHEET 9 OF 13	

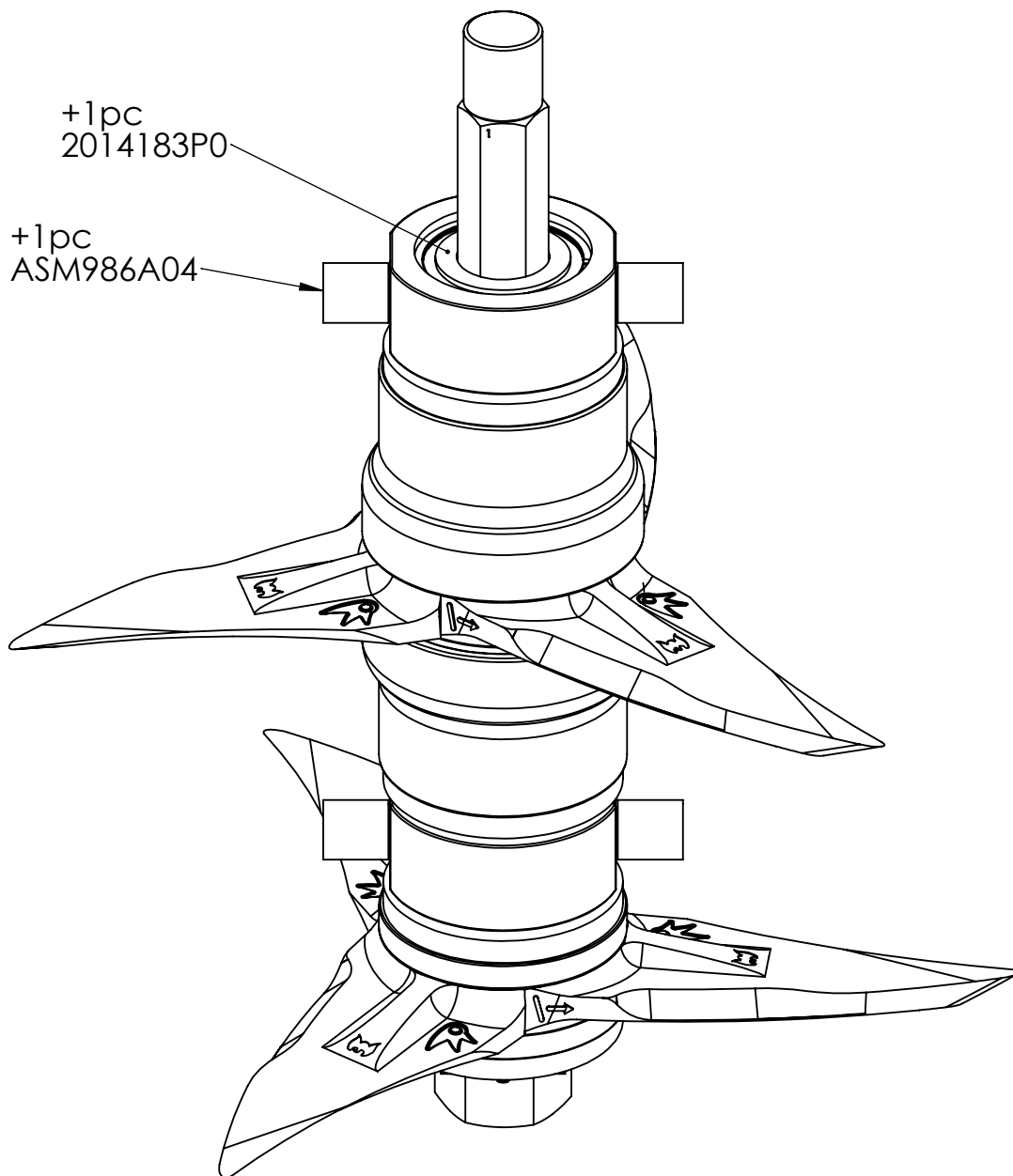

Assembly BOM Link: [ASM988A03.xls](#)
 (contains prints to constituent part prints)

Drawing Name: ASM988A03		REVISION 0 DATE 3/28/2016	PART NO. ASM988A03	DESCRIPTION: 3star Roller, CCW
A:		DEBUR AND BREAK SHARP EDGES UNLESS OTHERWISE SPECIFIED: DIMENSIONS ARE IN INCHES SURFACE FINISH: TOLERANCES: LINEAR: 1/16" ANGULAR: 2°	PROCESSES	WEIGHT: 30.44Lbs
B:			Assemble	Soil Regeneration Unlimited
C:			Grease	
D:				PROPRIETARY AND CONFIDENTIAL
E:				THE INFORMATION CONTAINED IN THIS DRAWING IS THE SOLE PROPERTY OF SOIL REGENERATION UNLIMITED. ANY REPRODUCTION IN PART OR AS A WHOLE WITHOUT THE WRITTEN PERMISSION OF SOIL REGENERATION UNLIMITED IS PROHIBITED.
NAME Daniel R. M.	SIGNATURE	A4	SCALE: 1:4	
		SHEET 10 OF 13		

Ridge aligned with spline marked 1

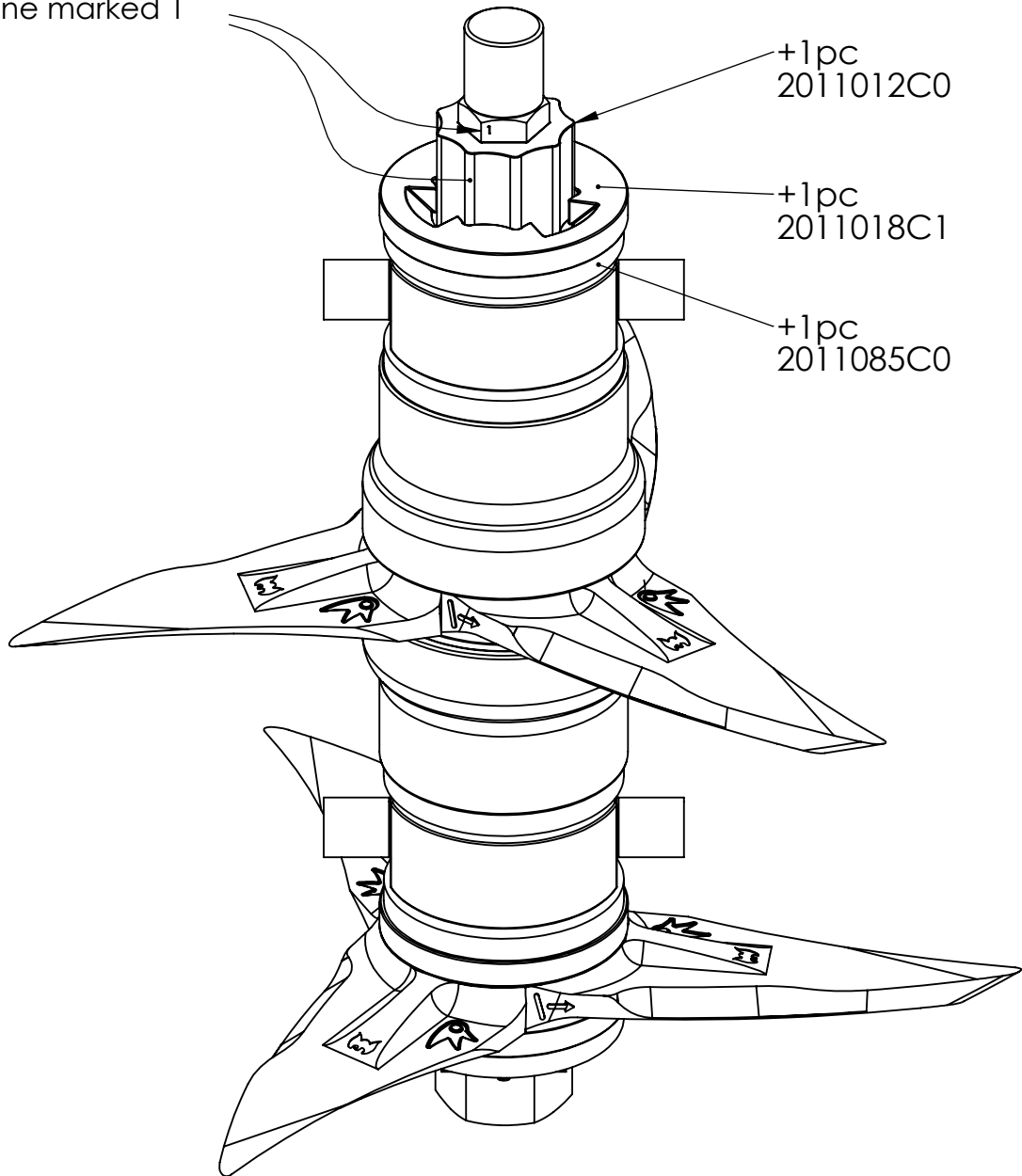

+1pc
2011012C0

+1pc
2011018C1

+1pc
2011085C0

Assembly BOM Link: [ASM988A03.xls](#)
(contains prints to constituent part prints)

Drawing Name: ASM988A03		REVISION 0	PART NO. ASM988A03		DESCRIPTION: 3star Roller, CCW
A:		DATE 3/28/2016	PROCESSES		WEIGHT: 30.44Lbs
B:		DEBUR AND BREAK SHARP EDGES UNLESS OTHERWISE SPECIFIED: DIMENSIONS ARE IN INCHES SURFACE FINISH: TOLERANCES: LINEAR: 1/16" ANGULAR: 2°	Assemble		Soil Regeneration Unlimited
C:			Grease		
D:			DO NOT SCALE DRAWING		PROPRIETARY AND CONFIDENTIAL THE INFORMATION CONTAINED IN THIS DRAWING IS THE SOLE PROPERTY OF SOIL REGENERATION UNLIMITED. ANY REPRODUCTION IN PART OR AS A WHOLE WITHOUT THE WRITTEN PERMISSION OF SOIL REGENERATION UNLIMITED IS PROHIBITED.
E:			A4 SCALE: 1:4		
NAME Daniel R. M.	SIGNATURE	SHEET 11 OF 13			

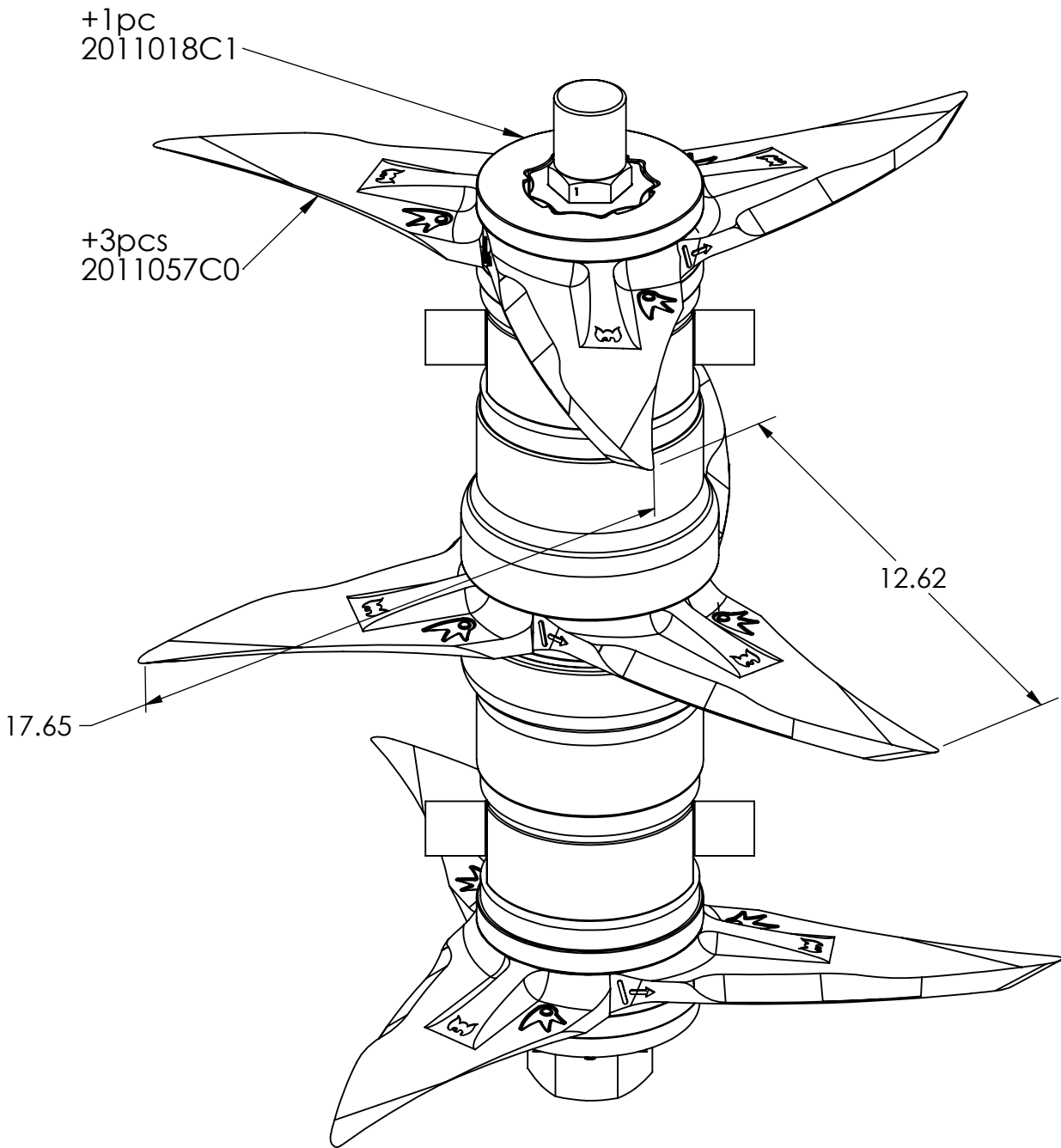

Drawing Name: ASM988A03		REVISION 0 DATE 3/28/2016	Assembly BOM Link: (contains prints to constituent part prints) ASM988A03.xls		PART NO. ASM988A03	DESCRIPTION: 3star Roller, CCW
A:		DEBUR AND BREAK SHARP EDGES UNLESS OTHERWISE SPECIFIED: DIMENSIONS ARE IN INCHES SURFACE FINISH: TOLERANCES: LINEAR: 1/16" ANGULAR: 2°	PROCESSES		WEIGHT: 30.44Lbs	
B:			Assemble		Soil Regeneration Unlimited	
C:			Grease			
D:			DO NOT SCALE DRAWING		PROPRIETARY AND CONFIDENTIAL THE INFORMATION CONTAINED IN THIS DRAWING IS THE SOLE PROPERTY OF SOIL REGENERATION UNLIMITED. ANY REPRODUCTION IN PART OR AS A WHOLE WITHOUT THE WRITTEN PERMISSION OF SOIL REGENERATION UNLIMITED IS PROHIBITED.	
E:			A4 SCALE: 1:4			
NAME Daniel R. M.	SIGNATURE	SHEET 12 OF 13				

STEP 12

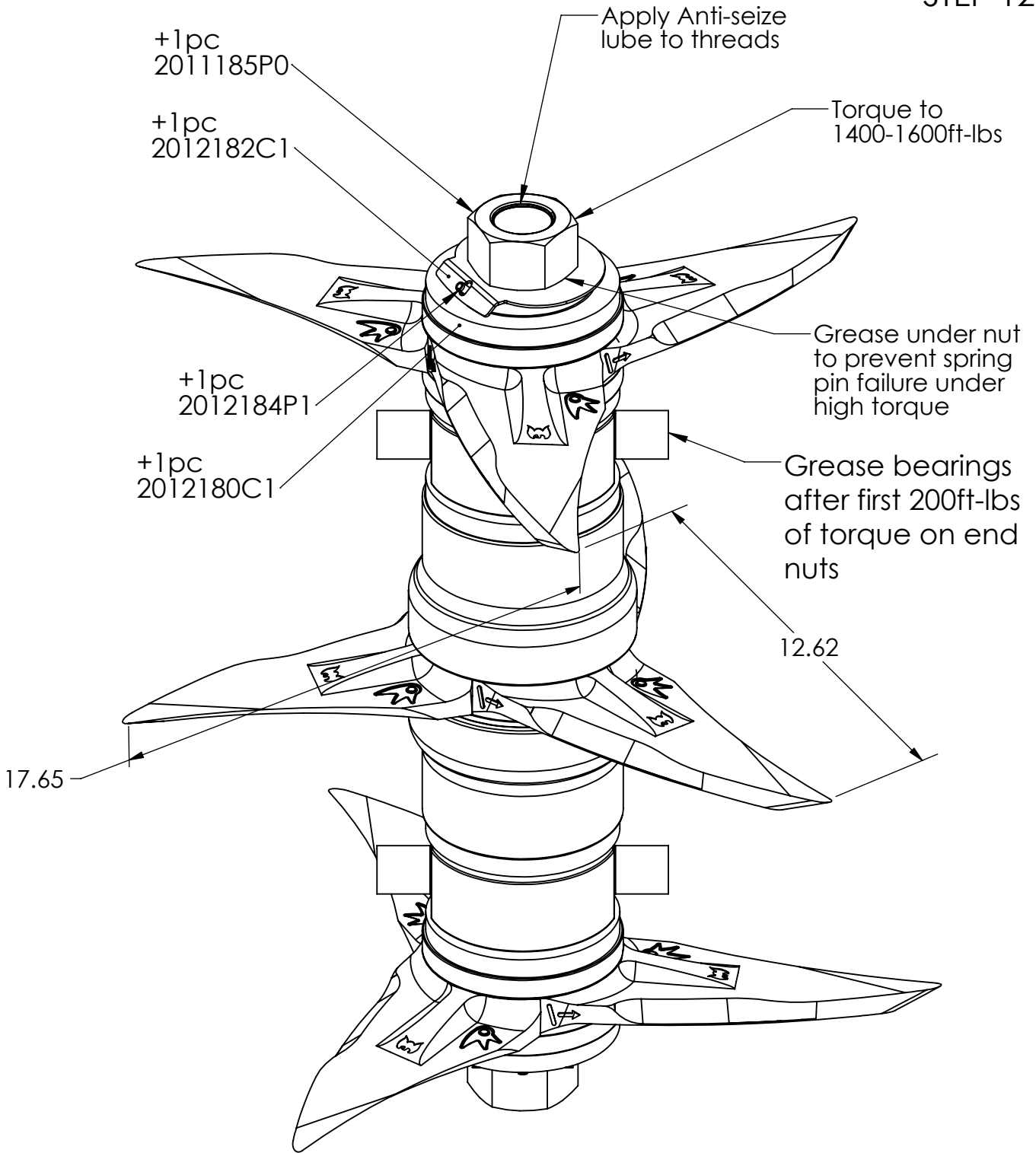

Assembly BOM Link: [ASM988A03.xls](#)
 (contains prints to constituent part prints)

Drawing Name: ASM988A03		REVISION 0 DATE 3/28/2016	PART NO. ASM988A03	DESCRIPTION: 3star Roller, CCW
A:		DEBUR AND BREAK SHARP EDGES UNLESS OTHERWISE SPECIFIED: DIMENSIONS ARE IN INCHES SURFACE FINISH: TOLERANCES: LINEAR: 1/16" ANGULAR: 2°	PROCESSES	WEIGHT: 30.44Lbs
B:			Assemble	Soil Regeneration Unlimited
C:			Grease	
D:			DO NOT SCALE DRAWING	PROPRIETARY AND CONFIDENTIAL THE INFORMATION CONTAINED IN THIS DRAWING IS THE SOLE PROPERTY OF SOIL REGENERATION UNLIMITED. ANY REPRODUCTION IN PART OR AS A WHOLE WITHOUT THE WRITTEN PERMISSION OF SOIL REGENERATION UNLIMITED IS PROHIBITED.
E:		A4	SCALE: 1:4	
NAME Daniel R. M.	SIGNATURE	SHEET 13 OF 13		