

ITEM NO.	PartNo	QTY.	Weight	Description	Material	Length
1	2011012C0	6	2.49	ROLLER HARTING RING DRIVER	80-55-06	
2	2011018C1	12	2.37	Harting Ring, Cast	80-55-06	
3	2011058C0	18	4.884	CW Tine, Tabs Base, hard-faced	2011014C2	
4	2011074C1	8	20.96	Short Spacer, Cast	65-45-12	
5	2011085C0	4	3.50	End Cap	80-55-06	
6	2011088C3	1	42.86	Arbor Bolt, 6star	BAR HEX-1.75 4140 ANLD	57.375
7	2011185P0	2	1.60	1-3/4"-12 Grade 8 Hex Nut	Grade 8 Steel	
8	2012180C1	2	3.49	End Cap, drilled	2011085C0	
9	2012182C1	2	0.27	Roller nut lock flange	SH-14GA	2
10	2012184P1	2	0.008	1/4" x 1" Zinc-Plated Steel Slotted Spring Pin, MCM# 90692A742	MCM# 90692A742	
11	2014183P0	3	0.13	Flat roller bearing washer, BOKERS# 422395	BOKERS# 422395	0.125
12	ASM986A04	2	9.23	Roller Bearing Unit		

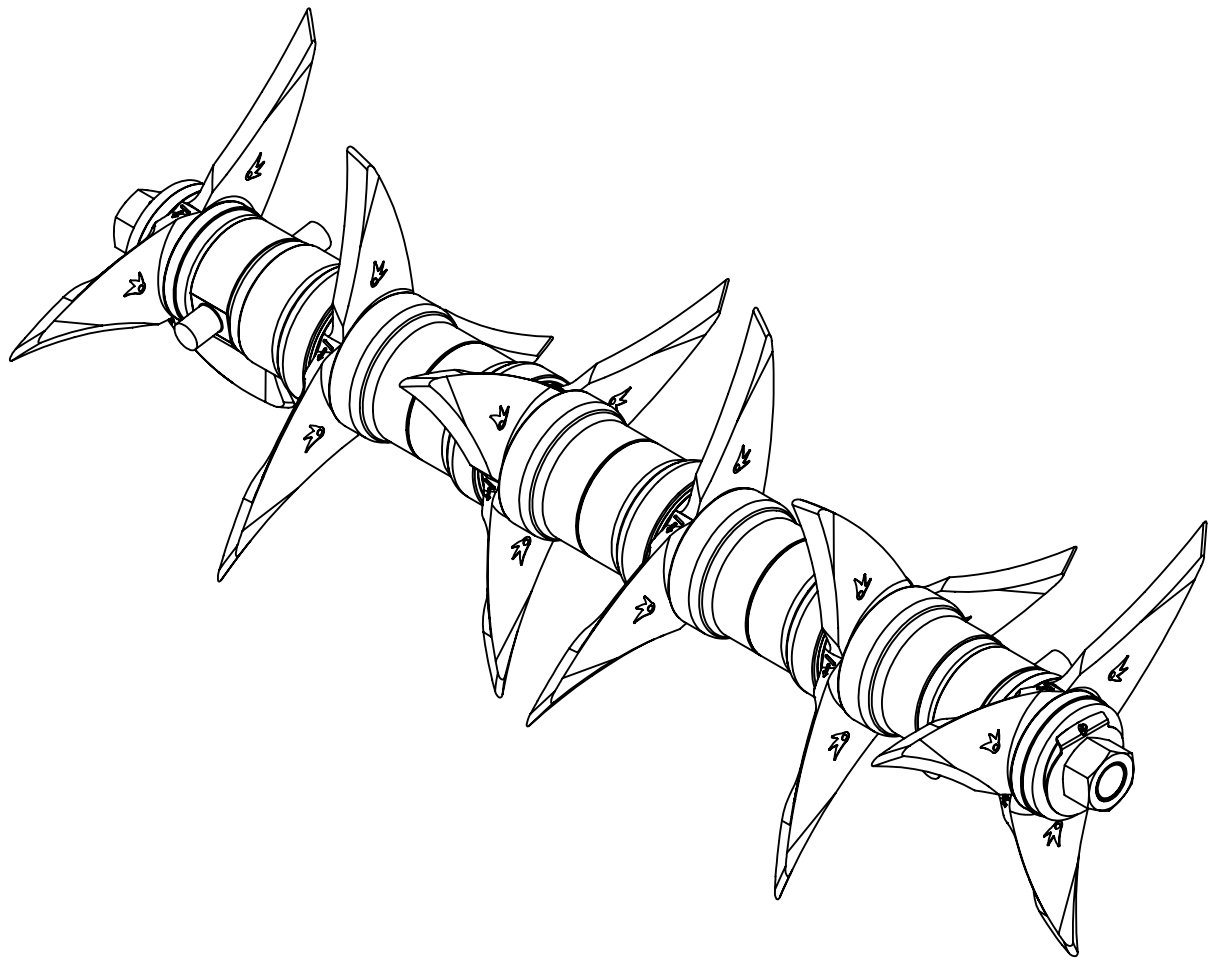

Assembly BOM Link: [ASM989A06.xls](#)
 (contains prints to constituent part prints)

Drawing Name: ASM989A06		REVISION 0	PART NO. ASM989A06		DESCRIPTION: 6star Roller, CW
A:		DATE 3/26/2016	PROCESSES		WEIGHT: 48.23Lbs
B:		DEBUR AND BREAK SHARP EDGES	Assemble		Soil Regeneration Unlimited
C:		UNLESS OTHERWISE SPECIFIED: DIMENSIONS ARE IN INCHES SURFACE FINISH: TOLERANCES: LINEAR: 1/16" ANGULAR: 2°	Grease		
D:		DO NOT SCALE DRAWING			PROPRIETARY AND CONFIDENTIAL
E:		A4	SCALE: 1:8		THE INFORMATION CONTAINED IN THIS DRAWING IS THE SOLE PROPERTY OF SOIL REGENERATION UNLIMITED. ANY REPRODUCTION IN PART OR AS A WHOLE WITHOUT THE WRITTEN PERMISSION OF SOIL REGENERATION UNLIMITED IS PROHIBITED.
NAME Daniel R. M.	SIGNATURE	SHEET 1 OF 19			

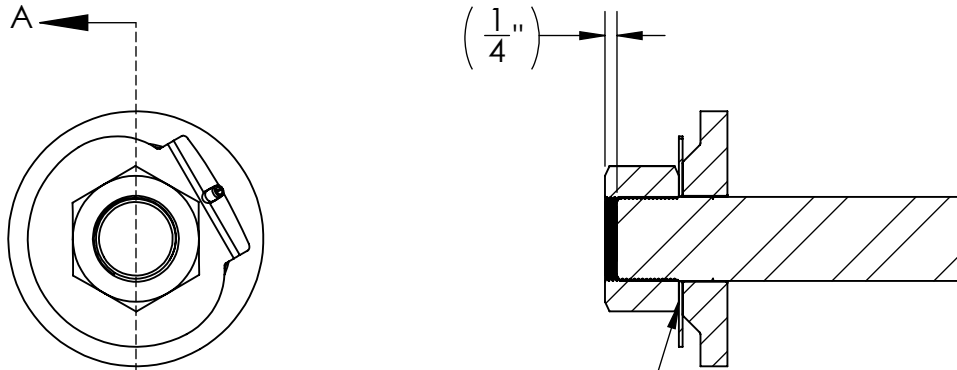

Grease under nut to prevent spring pin failure under high torque

SECTION A-A

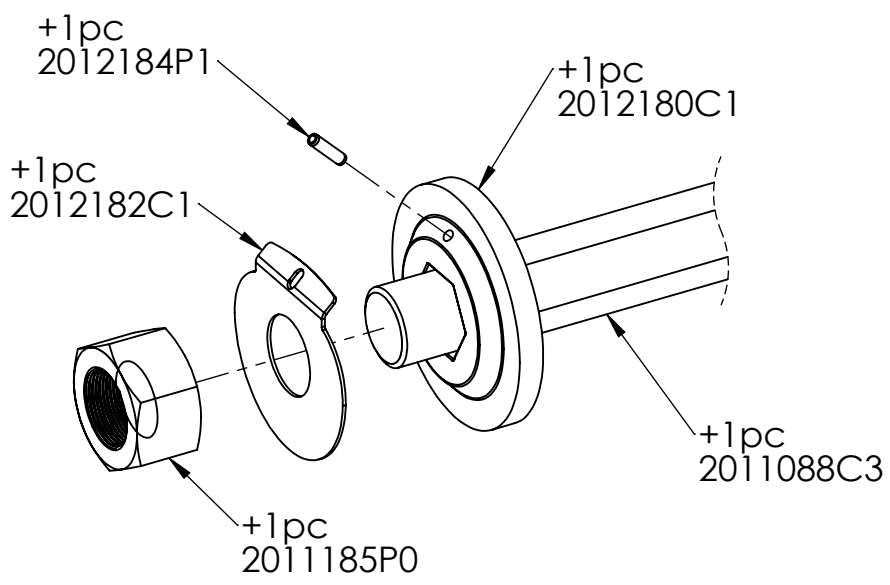
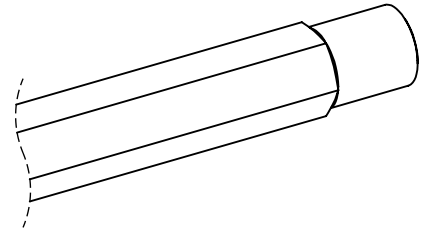

+1pc
2012184P1

+1pc
2012180C1

+1pc
2012182C1

+1pc
2011088C3

+1pc
2011185PO

Assembly BOM Link: ASM989A06.xls (contains prints to constituent part prints)		PART NO. <h1>ASM989A06</h1>		DESCRIPTION: 6star Roller, CW
Drawing Name: ASM989A06	REVISION 0 DATE 3/26/2016	DEBUR AND BREAK SHARP EDGES UNLESS OTHERWISE SPECIFIED: DIMENSIONS ARE IN INCHES SURFACE FINISH: TOLERANCES: LINEAR: 1/16" ANGULAR: 2°		WEIGHT: 48.23Lbs
A:		PROCESSES Assemble Grease		<h2>Soil Regeneration Unlimited</h2>
B:				
C:		DO NOT SCALE DRAWING		PROPRIETARY AND CONFIDENTIAL THE INFORMATION CONTAINED IN THIS DRAWING IS THE SOLE PROPERTY OF SOIL REGENERATION UNLIMITED. ANY REPRODUCTION IN PART OR AS A WHOLE WITHOUT THE WRITTEN PERMISSION OF SOIL REGENERATION UNLIMITED IS PROHIBITED.
D:		A4	SCALE: 1:4	
E:		SHEET 2 OF 19		
NAME Daniel R. M.	SIGNATURE			

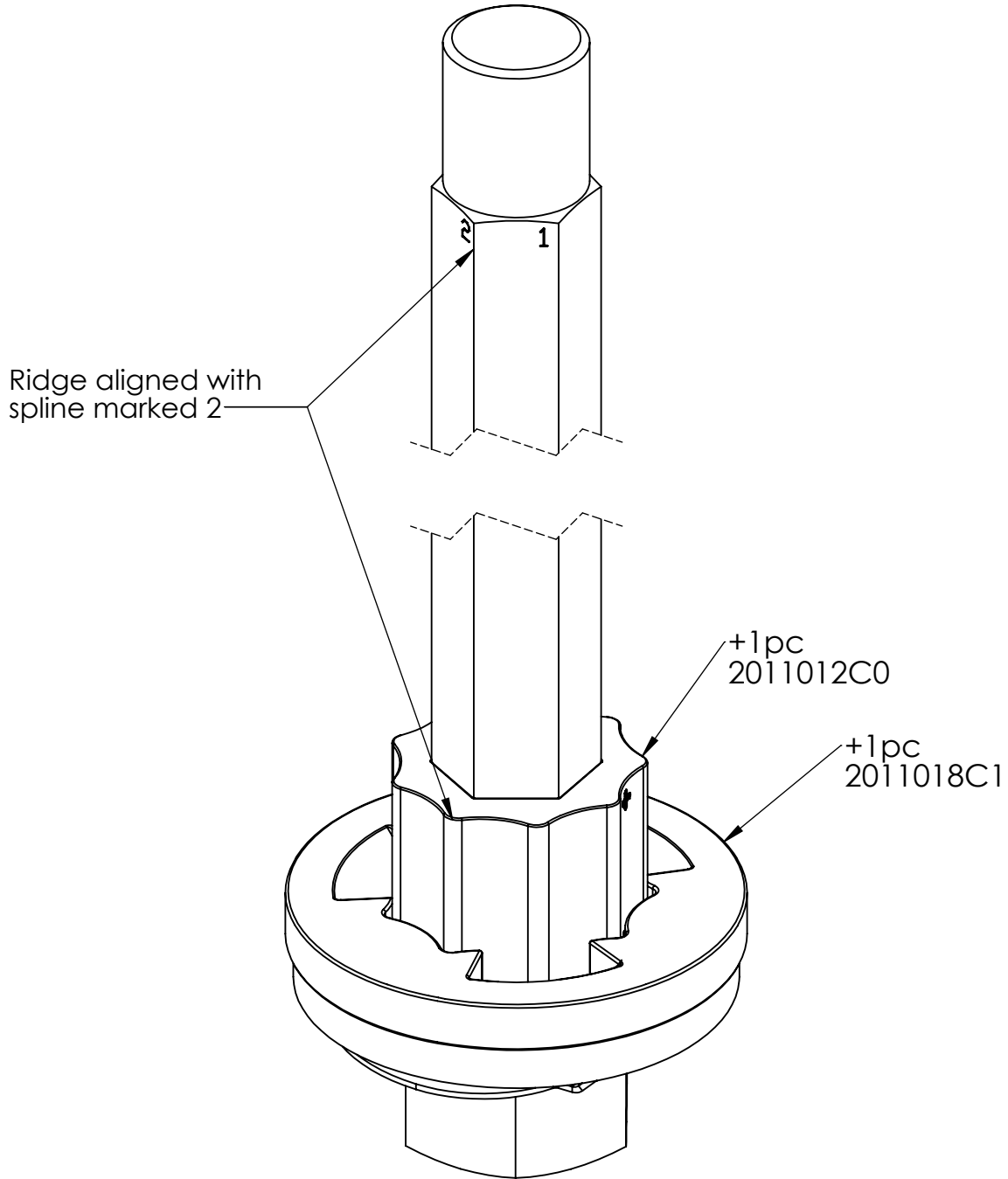

Assembly BOM Link: [ASM989A06.xls](#)
 (contains prints to constituent part prints)

Drawing Name: ASM989A06		REVISION 0	PART NO. ASM989A06		DESCRIPTION: 6star Roller, CW
A:		DATE 3/26/2016	PROCESSES		WEIGHT: 48.23Lbs
B:		DEBUR AND BREAK SHARP EDGES UNLESS OTHERWISE SPECIFIED: DIMENSIONS ARE IN INCHES SURFACE FINISH: TOLERANCES: LINEAR: 1/16" ANGULAR: 2°	Assemble		Soil Regeneration Unlimited
C:			Grease		
D:			DO NOT SCALE DRAWING		PROPRIETARY AND CONFIDENTIAL THE INFORMATION CONTAINED IN THIS DRAWING IS THE SOLE PROPERTY OF SOIL REGENERATION UNLIMITED. ANY REPRODUCTION IN PART OR AS A WHOLE WITHOUT THE WRITTEN PERMISSION OF SOIL REGENERATION UNLIMITED IS PROHIBITED.
E:			A4	SCALE: 1:2	
NAME Daniel R. M.	SIGNATURE	SHEET 3 OF 19			

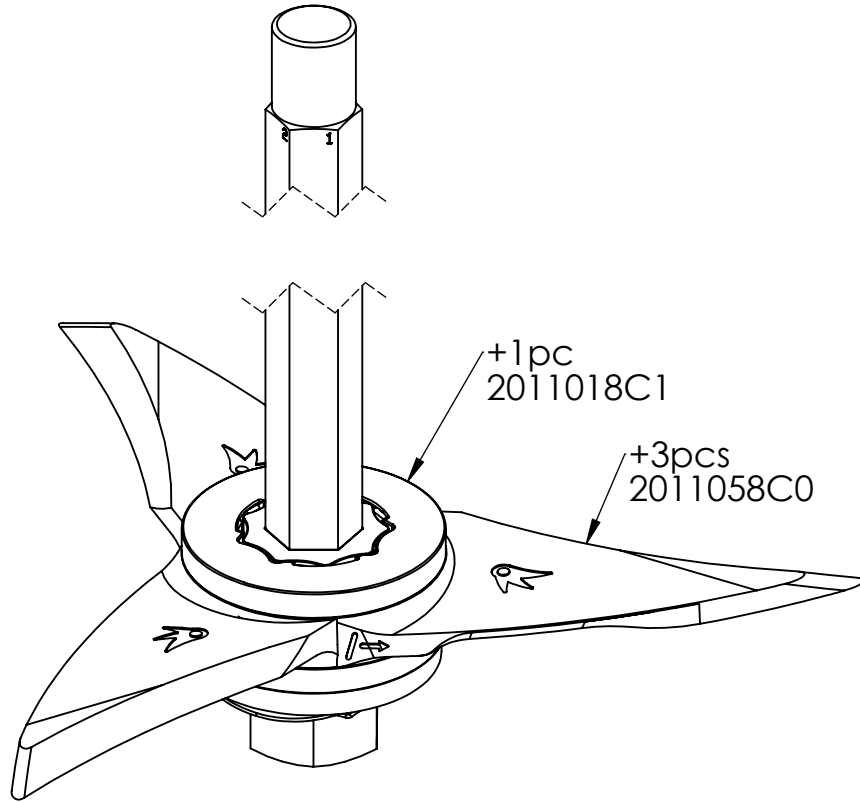

Assembly BOM Link: [ASM989A06.xls](#)
 (contains prints to constituent part prints)

Drawing Name: ASM989A06		REVISION 0	PART NO. ASM989A06		DESCRIPTION: 6star Roller, CW
A:		DATE 3/26/2016	PROCESSES		WEIGHT: 48.23Lbs
B:		DEBUR AND BREAK SHARP EDGES UNLESS OTHERWISE SPECIFIED: DIMENSIONS ARE IN INCHES SURFACE FINISH: TOLERANCES: LINEAR: 1/16" ANGULAR: 2°	Assemble		Soil Regeneration Unlimited
C:			Grease		
D:			DO NOT SCALE DRAWING		PROPRIETARY AND CONFIDENTIAL THE INFORMATION CONTAINED IN THIS DRAWING IS THE SOLE PROPERTY OF SOIL REGENERATION UNLIMITED. ANY REPRODUCTION IN PART OR AS A WHOLE WITHOUT THE WRITTEN PERMISSION OF SOIL REGENERATION UNLIMITED IS PROHIBITED.
E:			A4 SCALE: 1:2		
NAME Daniel R. M.	SIGNATURE		SHEET 4 OF 19		

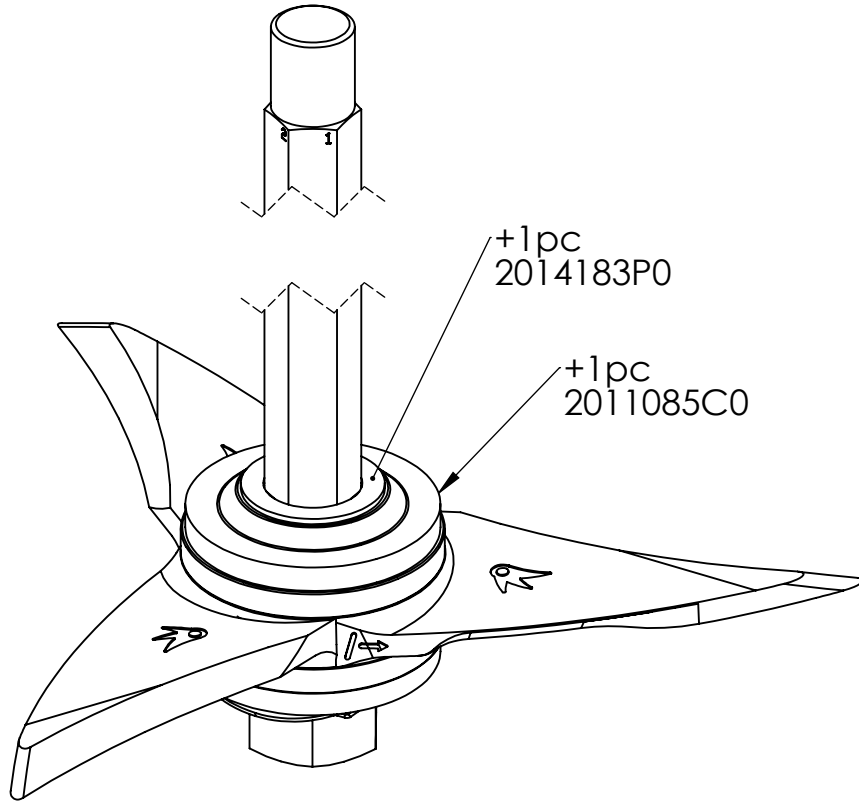

Assembly BOM Link: [ASM989A06.xls](#)
 (contains prints to constituent part prints)

Drawing Name: ASM989A06		REVISION 0	PART NO. ASM989A06		DESCRIPTION: 6star Roller, CW
A:		DATE 3/26/2016	PROCESSES		WEIGHT: 48.23Lbs
B:		DEBUR AND BREAK SHARP EDGES UNLESS OTHERWISE SPECIFIED: DIMENSIONS ARE IN INCHES SURFACE FINISH: TOLERANCES: LINEAR: 1/16" ANGULAR: 2°	Assemble		Soil Regeneration Unlimited
C:			Grease		
D:			DO NOT SCALE DRAWING		PROPRIETARY AND CONFIDENTIAL THE INFORMATION CONTAINED IN THIS DRAWING IS THE SOLE PROPERTY OF SOIL REGENERATION UNLIMITED. ANY REPRODUCTION IN PART OR AS A WHOLE WITHOUT THE WRITTEN PERMISSION OF SOIL REGENERATION UNLIMITED IS PROHIBITED.
E:			A4 SCALE: 1:2		
NAME Daniel R. M.	SIGNATURE		SHEET 5 OF 19		

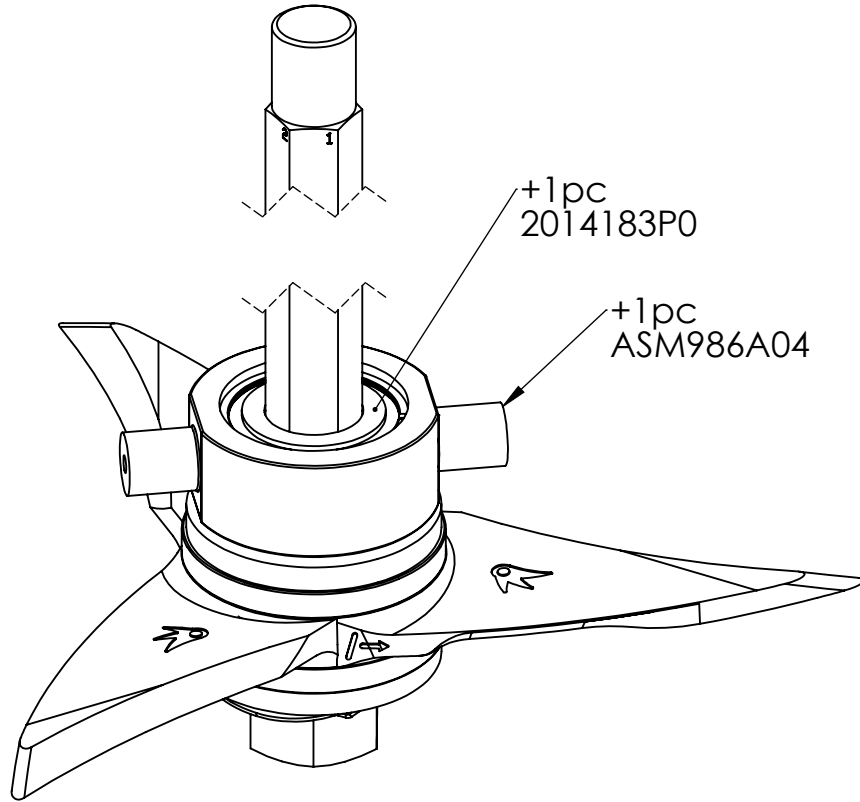

Assembly BOM Link: [ASM989A06.xls](#)
 (contains prints to constituent part prints)

Drawing Name: ASM989A06		REVISION 0	PART NO. ASM989A06		DESCRIPTION: 6star Roller, CW
A:		DATE 3/26/2016	PROCESSES		WEIGHT: 48.23Lbs
B:		DEBUR AND BREAK SHARP EDGES	Assemble		Soil Regeneration Unlimited
C:		UNLESS OTHERWISE SPECIFIED: DIMENSIONS ARE IN INCHES SURFACE FINISH: TOLERANCES: LINEAR: 1/16" ANGULAR: 2°	Grease		
D:		DO NOT SCALE DRAWING			PROPRIETARY AND CONFIDENTIAL
E:		A4	SCALE: 1:2		THE INFORMATION CONTAINED IN THIS DRAWING IS THE SOLE PROPERTY OF SOIL REGENERATION UNLIMITED. ANY REPRODUCTION IN PART OR AS A WHOLE WITHOUT THE WRITTEN PERMISSION OF SOIL REGENERATION UNLIMITED IS PROHIBITED.
NAME Daniel R. M.	SIGNATURE	SHEET 6 OF 19			

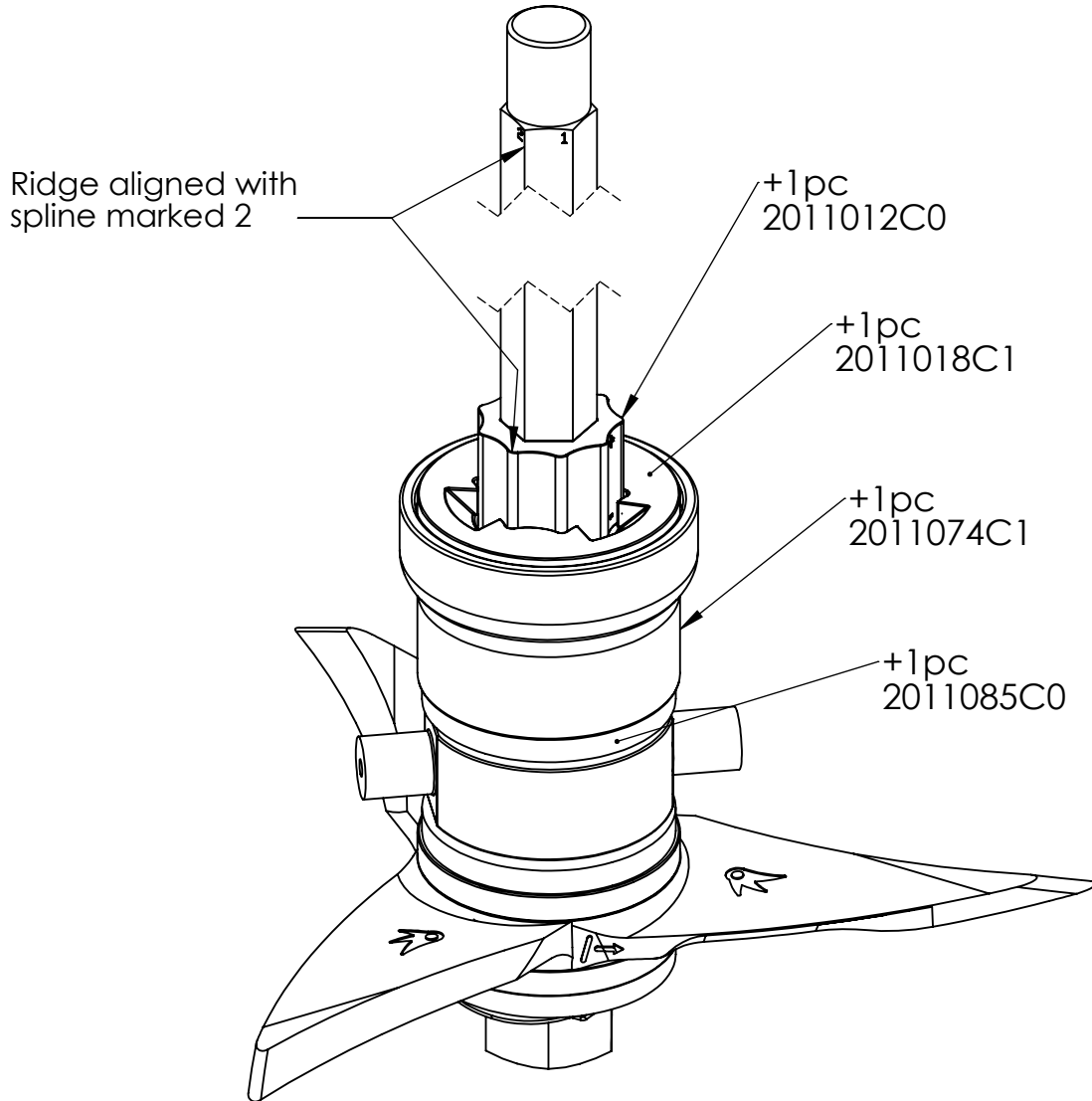

Assembly BOM Link: [ASM989A06.xls](#)
 (contains prints to constituent part prints)

Drawing Name: ASM989A06		REVISION 0	PART NO. ASM989A06		DESCRIPTION: 6star Roller, CW
A:		DATE 3/26/2016	PROCESSES		WEIGHT: 48.23Lbs
B:		DEBUR AND BREAK SHARP EDGES UNLESS OTHERWISE SPECIFIED: DIMENSIONS ARE IN INCHES SURFACE FINISH: TOLERANCES: LINEAR: 1/16" ANGULAR: 2°	Assemble		Soil Regeneration Unlimited
C:			Grease		
D:			DO NOT SCALE DRAWING		PROPRIETARY AND CONFIDENTIAL THE INFORMATION CONTAINED IN THIS DRAWING IS THE SOLE PROPERTY OF SOIL REGENERATION UNLIMITED. ANY REPRODUCTION IN PART OR AS A WHOLE WITHOUT THE WRITTEN PERMISSION OF SOIL REGENERATION UNLIMITED IS PROHIBITED.
E:			A4 SCALE: 1:2		
NAME Daniel R. M.	SIGNATURE	SHEET 7 OF 19			

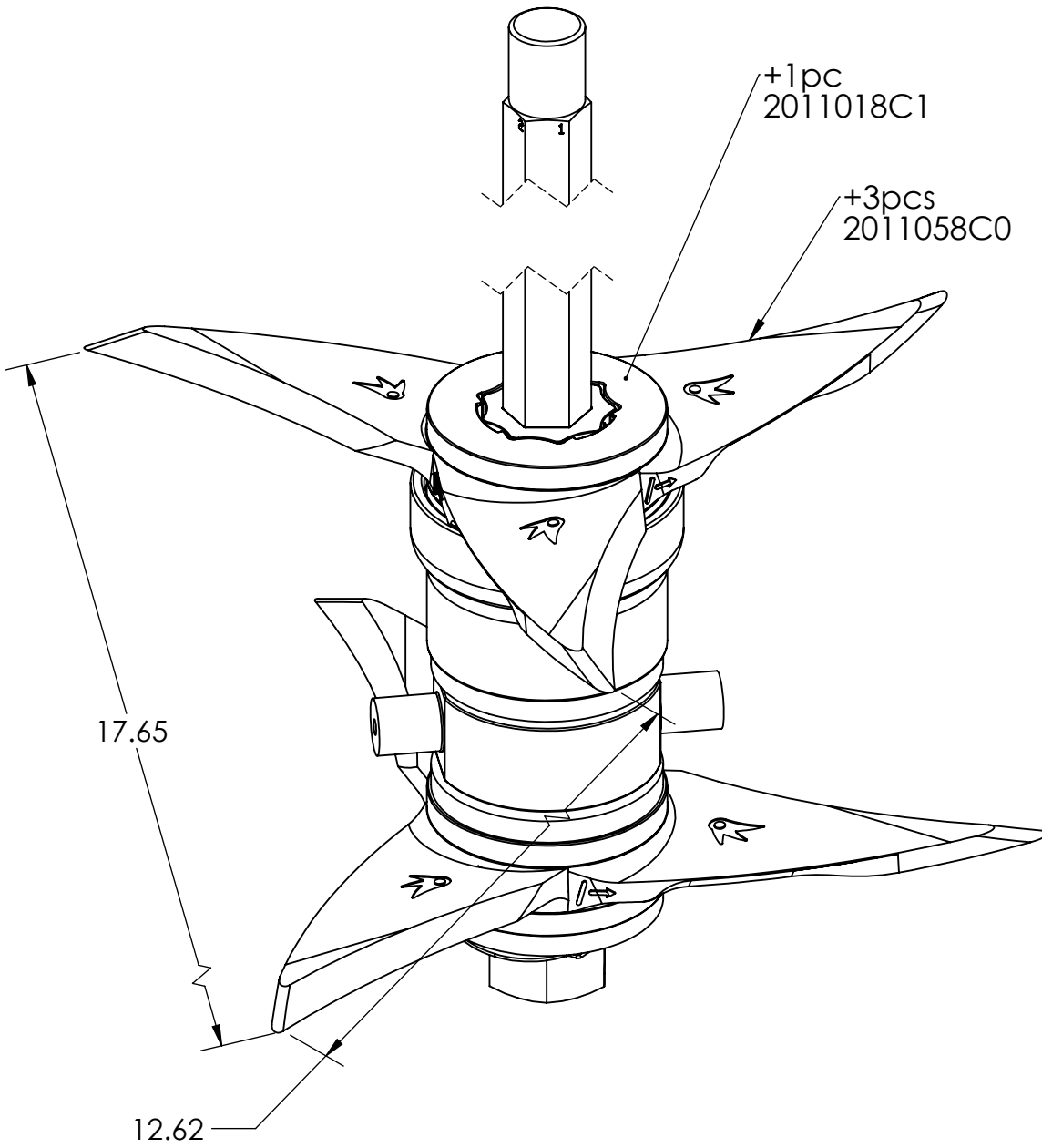

Assembly BOM Link: [ASM989A06.xls](#)
 (contains prints to constituent part prints)

Drawing Name: ASM989A06		REVISION 0	PART NO. ASM989A06		DESCRIPTION: 6star Roller, CW
A:		DATE 3/26/2016	PROCESSES		WEIGHT: 48.23Lbs
B:		DEBUR AND BREAK SHARP EDGES UNLESS OTHERWISE SPECIFIED: DIMENSIONS ARE IN INCHES SURFACE FINISH: TOLERANCES: LINEAR: 1/16" ANGULAR: 2°	Assemble		Soil Regeneration Unlimited
C:			Grease		
D:			DO NOT SCALE DRAWING		PROPRIETARY AND CONFIDENTIAL THE INFORMATION CONTAINED IN THIS DRAWING IS THE SOLE PROPERTY OF SOIL REGENERATION UNLIMITED. ANY REPRODUCTION IN PART OR AS A WHOLE WITHOUT THE WRITTEN PERMISSION OF SOIL REGENERATION UNLIMITED IS PROHIBITED.
E:		A4	SCALE: 1:2		
NAME Daniel R. M.	SIGNATURE		SHEET 8 OF 19		

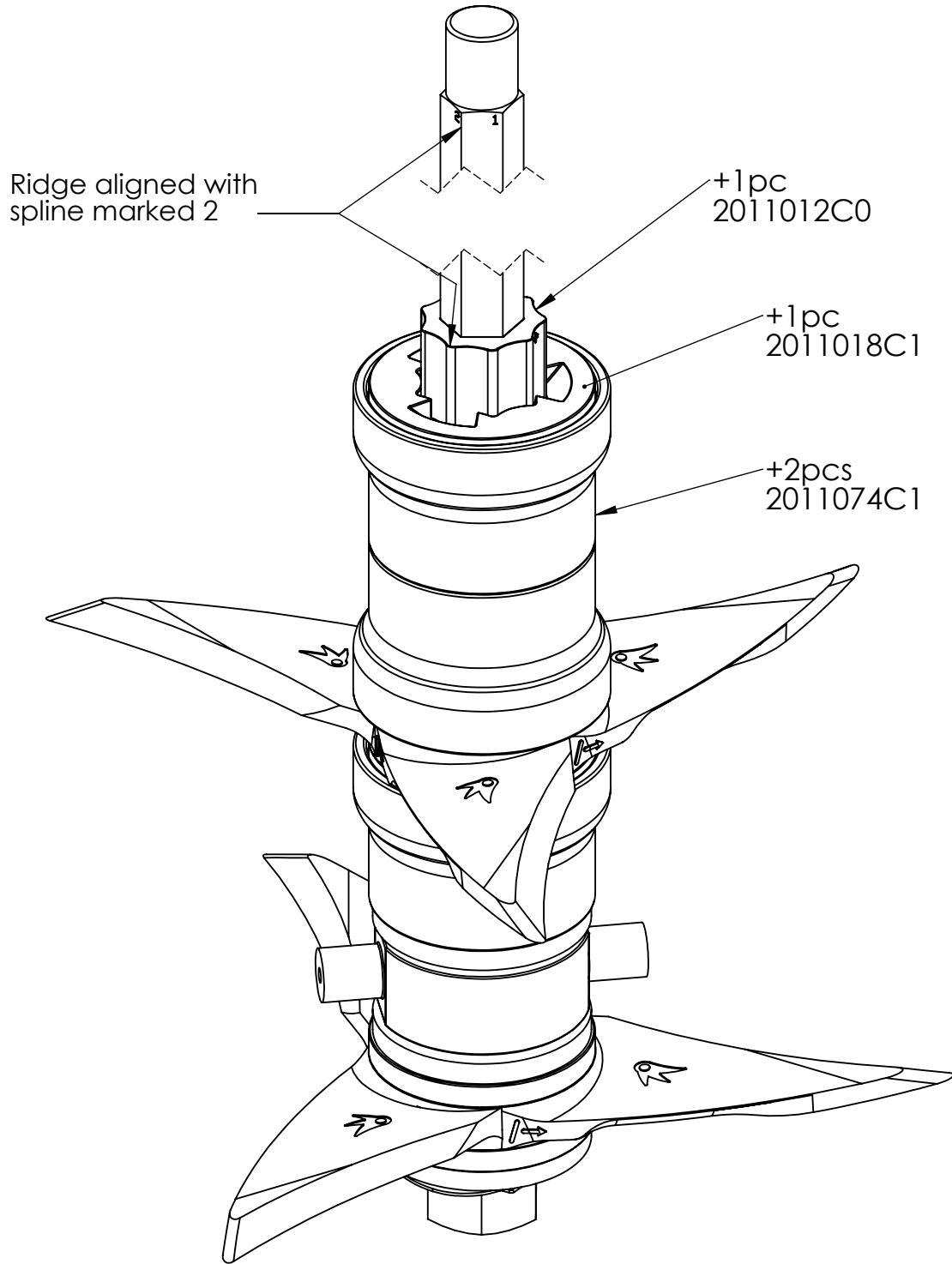

Assembly BOM Link: [ASM989A06.xls](#)
 (contains prints to constituent part prints)

Drawing Name: ASM989A06		REVISION 0	PART NO. ASM989A06		DESCRIPTION: 6star Roller, CW
A:		DATE 3/26/2016	PROCESSES		WEIGHT: 48.23Lbs
B:		DEBUR AND BREAK SHARP EDGES UNLESS OTHERWISE SPECIFIED: DIMENSIONS ARE IN INCHES SURFACE FINISH: TOLERANCES: LINEAR: 1/16" ANGULAR: 2°	Assemble		Soil Regeneration Unlimited
C:			Grease		
D:			DO NOT SCALE DRAWING		PROPRIETARY AND CONFIDENTIAL THE INFORMATION CONTAINED IN THIS DRAWING IS THE SOLE PROPERTY OF SOIL REGENERATION UNLIMITED. ANY REPRODUCTION IN PART OR AS A WHOLE WITHOUT THE WRITTEN PERMISSION OF SOIL REGENERATION UNLIMITED IS PROHIBITED.
E:			A4	SCALE: 1:2	
NAME Daniel R. M.	SIGNATURE	SHEET 9 OF 19			

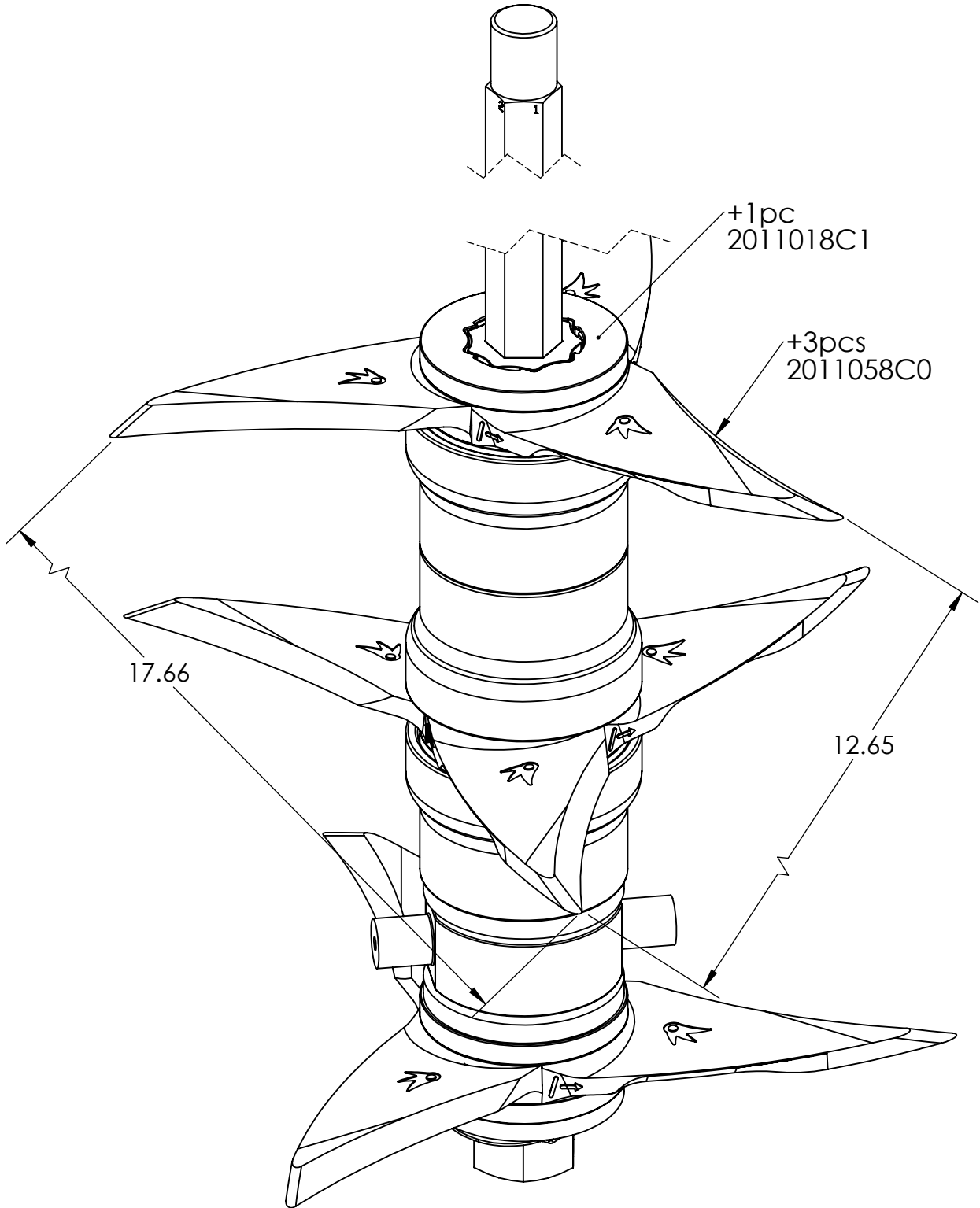

Assembly BOM Link: [ASM989A06.xls](#)
 (contains prints to constituent part prints)

Drawing Name: ASM989A06		REVISION 0	PART NO. ASM989A06		DESCRIPTION: 6star Roller, CW
A:		DATE 3/26/2016	PROCESSES		WEIGHT: 48.23Lbs
B:		DEBUR AND BREAK SHARP EDGES UNLESS OTHERWISE SPECIFIED: DIMENSIONS ARE IN INCHES SURFACE FINISH: TOLERANCES: LINEAR: 1/16" ANGULAR: 2°	Assemble		Soil Regeneration Unlimited
C:			Grease		
D:			DO NOT SCALE DRAWING		PROPRIETARY AND CONFIDENTIAL THE INFORMATION CONTAINED IN THIS DRAWING IS THE SOLE PROPERTY OF SOIL REGENERATION UNLIMITED. ANY REPRODUCTION IN PART OR AS A WHOLE WITHOUT THE WRITTEN PERMISSION OF SOIL REGENERATION UNLIMITED IS PROHIBITED.
E:			A4	SCALE: 1:2	
NAME Daniel R. M.	SIGNATURE	SHEET 10 OF 19			

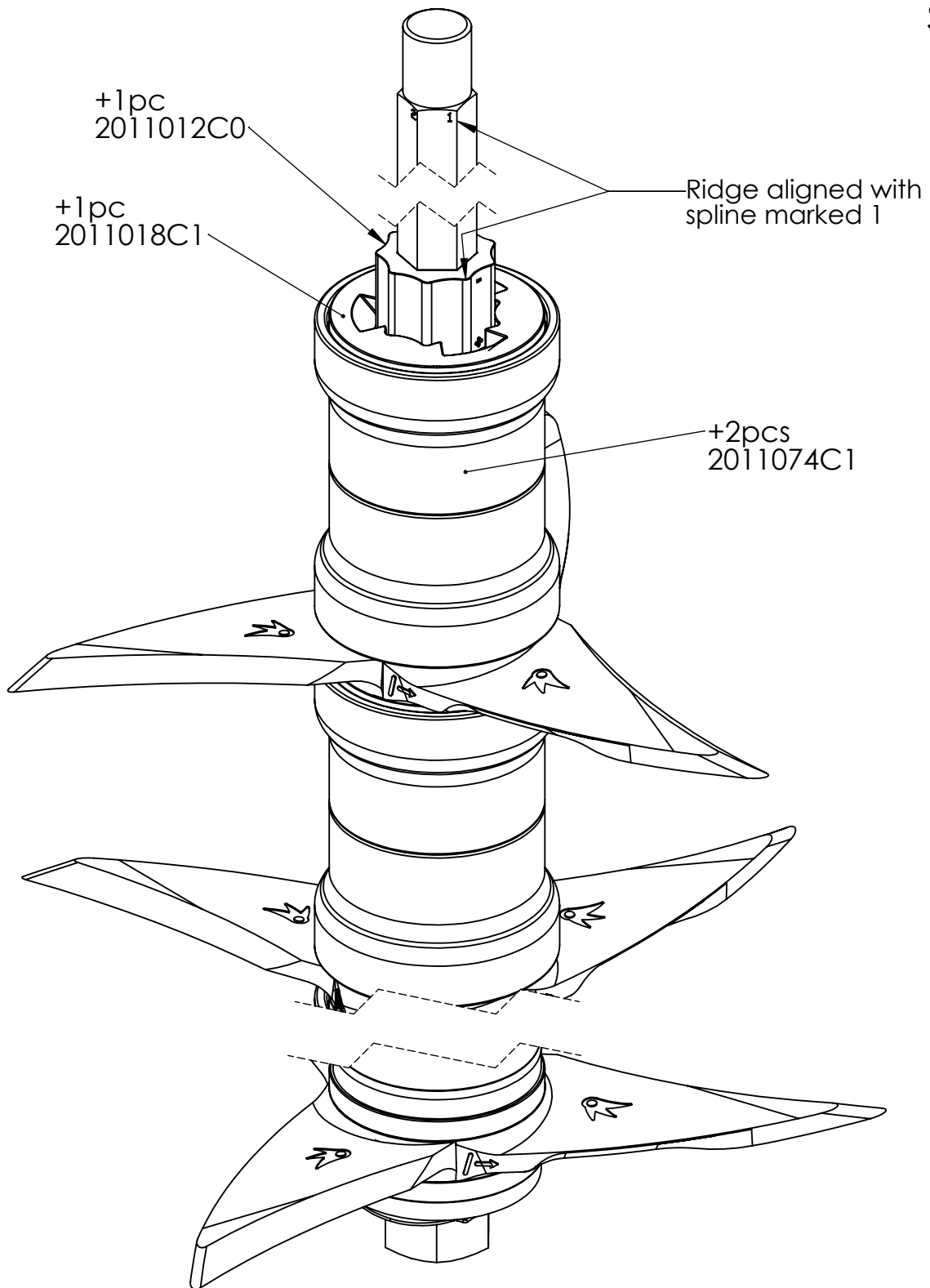

Assembly BOM Link: [ASM989A06.xls](#)
 (contains prints to constituent part prints)

Drawing Name: ASM989A06		REVISION 0	PART NO. ASM989A06		DESCRIPTION: 6star Roller, CW
A:		DATE 3/26/2016	PROCESSES		WEIGHT: 48.23Lbs
B:		DEBUR AND BREAK SHARP EDGES UNLESS OTHERWISE SPECIFIED: DIMENSIONS ARE IN INCHES SURFACE FINISH: TOLERANCES: LINEAR: 1/16" ANGULAR: 2°	Assemble		Soil Regeneration Unlimited
C:			Grease		
D:			DO NOT SCALE DRAWING		PROPRIETARY AND CONFIDENTIAL THE INFORMATION CONTAINED IN THIS DRAWING IS THE SOLE PROPERTY OF SOIL REGENERATION UNLIMITED. ANY REPRODUCTION IN PART OR AS A WHOLE WITHOUT THE WRITTEN PERMISSION OF SOIL REGENERATION UNLIMITED IS PROHIBITED.
E:			A4	SCALE: 1:2	
NAME Daniel R. M.	SIGNATURE	SHEET 11 OF 19			

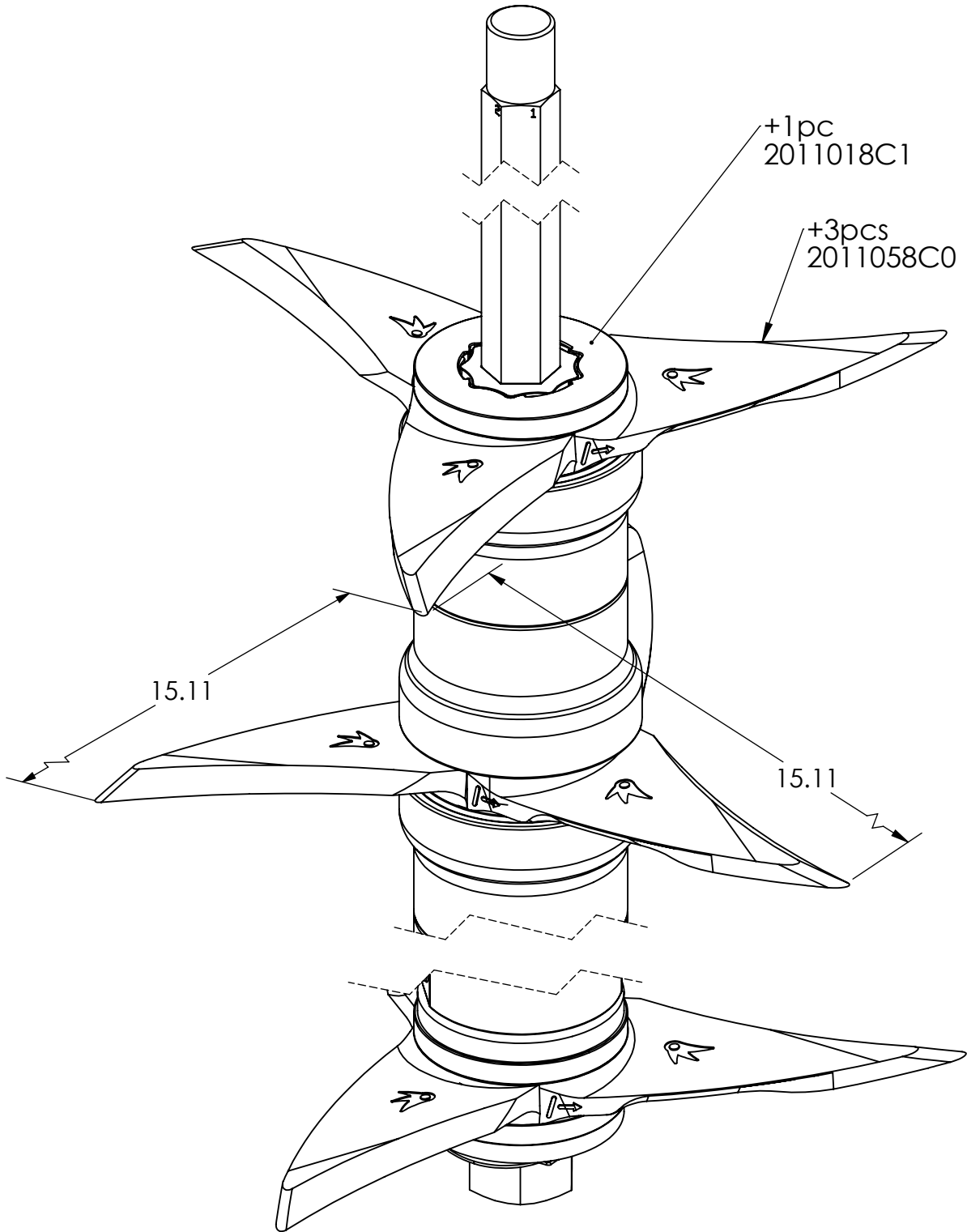

Assembly BOM Link: [ASM989A06.xls](#)
 (contains prints to constituent part prints)

Drawing Name: ASM989A06		REVISION 0	PART NO. ASM989A06		DESCRIPTION: 6star Roller, CW
A:		DATE 3/26/2016	PROCESSES		WEIGHT: 48.23Lbs
B:		DEBUR AND BREAK SHARP EDGES UNLESS OTHERWISE SPECIFIED: DIMENSIONS ARE IN INCHES SURFACE FINISH: TOLERANCES: LINEAR: 1/16" ANGULAR: 2°	Assemble		Soil Regeneration Unlimited
C:			Grease		
D:			DO NOT SCALE DRAWING		PROPRIETARY AND CONFIDENTIAL THE INFORMATION CONTAINED IN THIS DRAWING IS THE SOLE PROPERTY OF SOIL REGENERATION UNLIMITED. ANY REPRODUCTION IN PART OR AS A WHOLE WITHOUT THE WRITTEN PERMISSION OF SOIL REGENERATION UNLIMITED IS PROHIBITED.
E:			A4	SCALE: 1:2	
NAME Daniel R. M.	SIGNATURE		SHEET 12 OF 19		

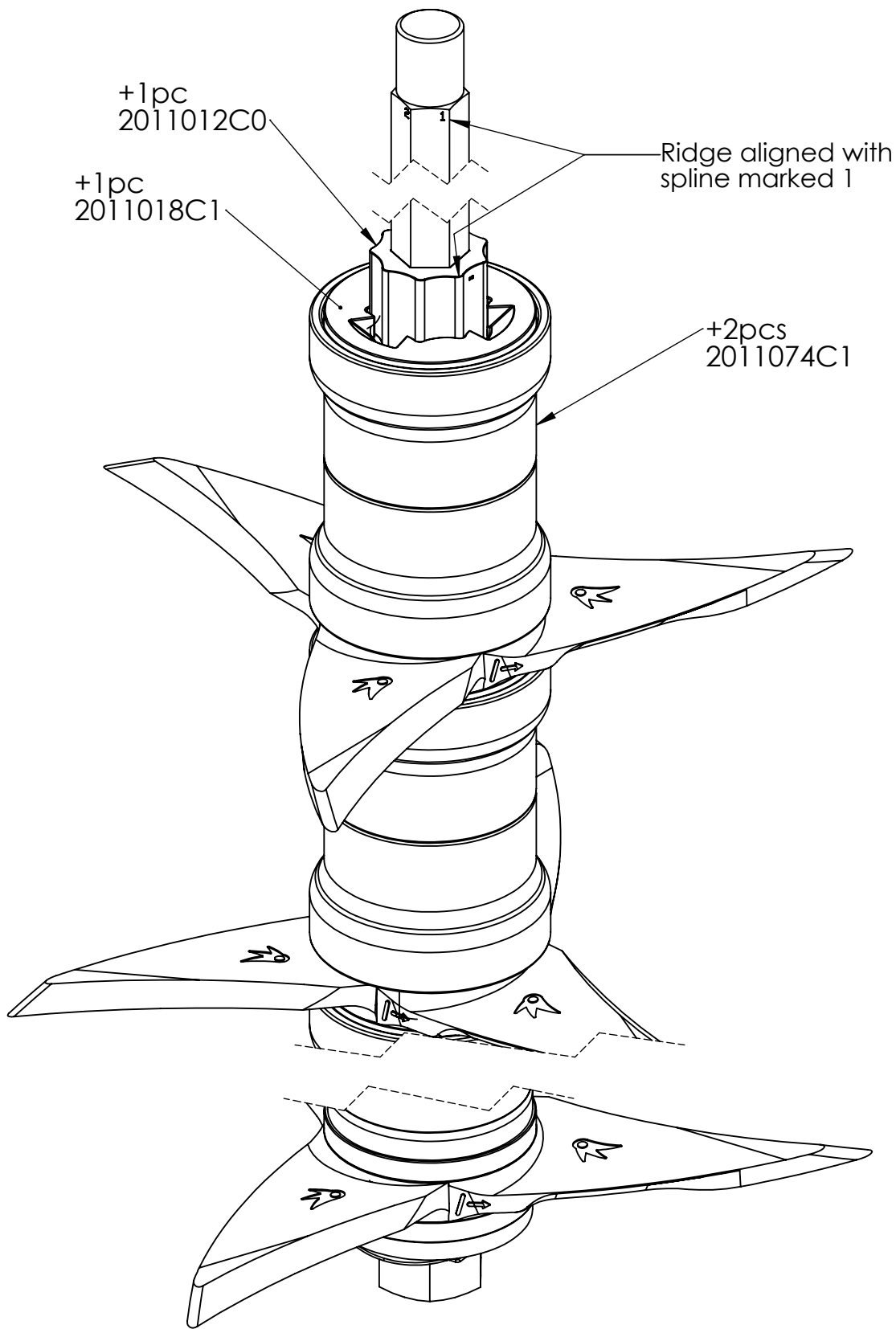

Assembly BOM Link: [ASM989A06.xls](#)
 (contains prints to constituent part prints)

Drawing Name: ASM989A06		REVISION 0 DATE 3/26/2016	PART NO. ASM989A06	DESCRIPTION: 6star Roller, CW
A:		DEBUR AND BREAK SHARP EDGES UNLESS OTHERWISE SPECIFIED: DIMENSIONS ARE IN INCHES SURFACE FINISH: TOLERANCES: LINEAR: 1/16" ANGULAR: 2°	PROCESSES	WEIGHT: 48.23Lbs
B:			Assemble	Soil Regeneration Unlimited
C:			Grease	
D:			DO NOT SCALE DRAWING	PROPRIETARY AND CONFIDENTIAL
E:			A4 SCALE: 1:2	THE INFORMATION CONTAINED IN THIS DRAWING IS THE SOLE PROPERTY OF SOIL REGENERATION UNLIMITED. ANY REPRODUCTION IN PART OR AS A WHOLE WITHOUT THE WRITTEN PERMISSION OF SOIL REGENERATION UNLIMITED IS PROHIBITED.
NAME Daniel R. M.	SIGNATURE	SHEET 13 OF 19		

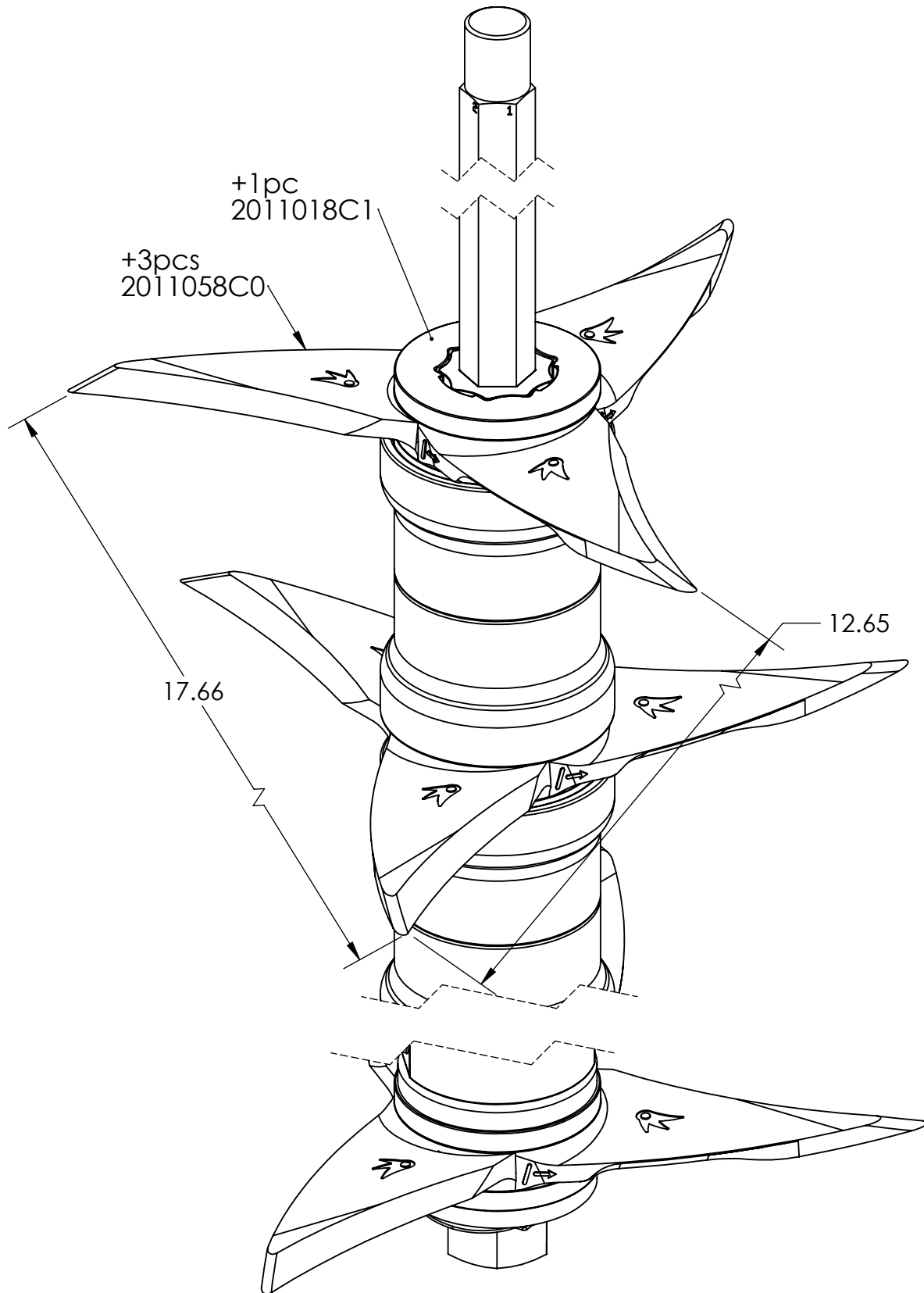

Assembly BOM Link: [ASM989A06.xls](#)
 (contains prints to constituent part prints)

Drawing Name: ASM989A06		REVISION 0	PART NO. ASM989A06		DESCRIPTION: 6star Roller, CW
A:		DATE 3/26/2016	PROCESSES		WEIGHT: 48.23Lbs
B:		DEBUR AND BREAK SHARP EDGES UNLESS OTHERWISE SPECIFIED: DIMENSIONS ARE IN INCHES SURFACE FINISH: TOLERANCES: LINEAR: 1/16" ANGULAR: 2°	Assemble		Soil Regeneration Unlimited
C:			Grease		
D:			DO NOT SCALE DRAWING		PROPRIETARY AND CONFIDENTIAL THE INFORMATION CONTAINED IN THIS DRAWING IS THE SOLE PROPERTY OF SOIL REGENERATION UNLIMITED. ANY REPRODUCTION IN PART OR AS A WHOLE WITHOUT THE WRITTEN PERMISSION OF SOIL REGENERATION UNLIMITED IS PROHIBITED.
E:			A4 SCALE: 1:2		
NAME Daniel R. M.	SIGNATURE	SHEET 14 OF 19			

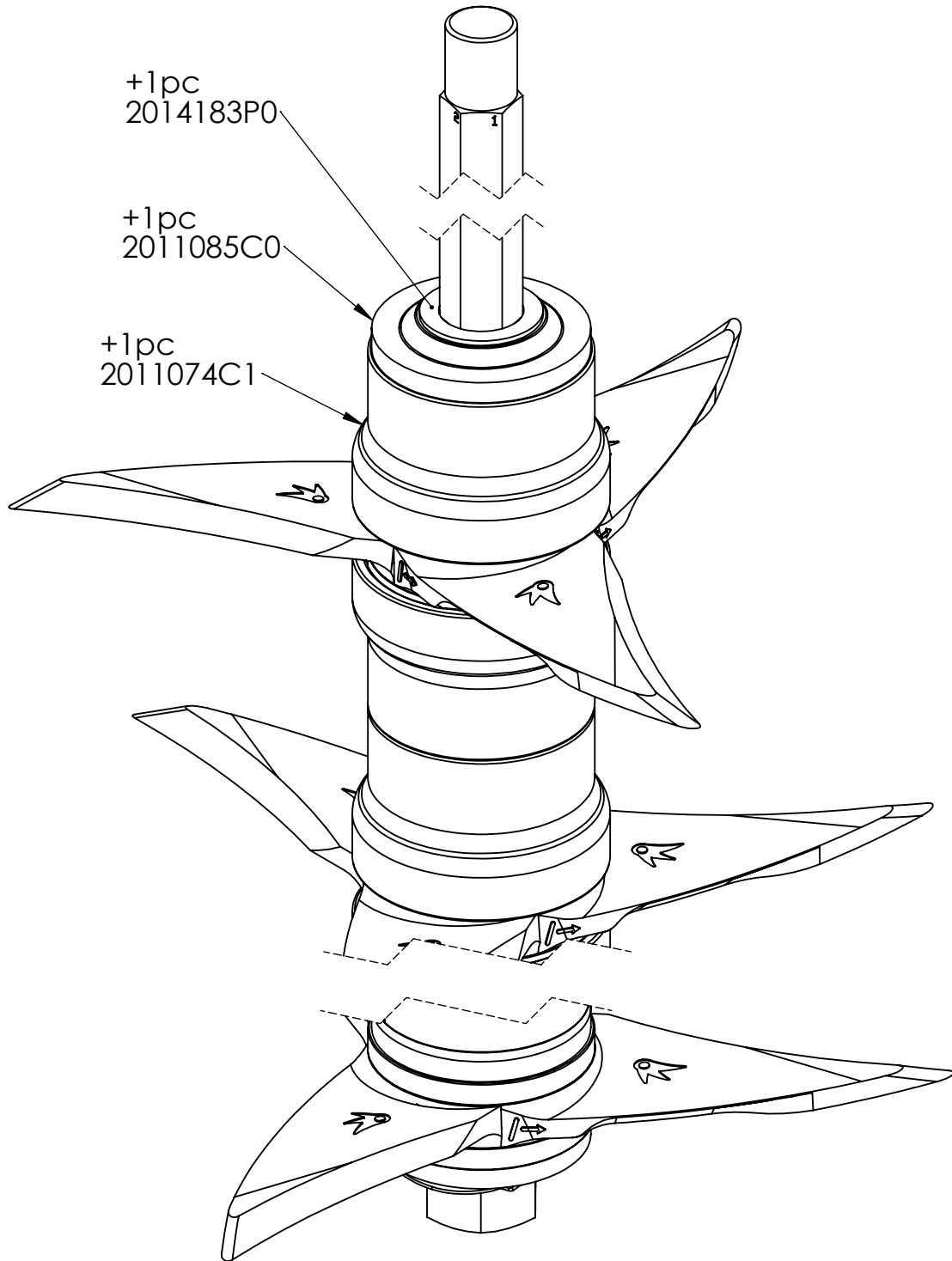

Assembly BOM Link: [ASM989A06.xls](#)
 (contains prints to constituent part prints)

Drawing Name: ASM989A06		REVISION 0	PART NO. ASM989A06		DESCRIPTION: 6star Roller, CW
DATE 3/26/2016		DEBUR AND BREAK SHARP EDGES		WEIGHT: 48.23Lbs	
A:		UNLESS OTHERWISE SPECIFIED: DIMENSIONS ARE IN INCHES		Soil Regeneration Unlimited	
B:		SURFACE FINISH:		PROPRIETARY AND CONFIDENTIAL	
C:		TOLERANCES: LINEAR: 1/16" ANGULAR: 2°		THE INFORMATION CONTAINED IN THIS DRAWING IS THE SOLE PROPERTY OF SOIL REGENERATION UNLIMITED. ANY REPRODUCTION IN PART OR AS A WHOLE WITHOUT THE WRITTEN PERMISSION OF SOIL REGENERATION UNLIMITED IS PROHIBITED.	
D:		DO NOT SCALE DRAWING			
E:		A4 SCALE: 1:2			
NAME Daniel R. M.	SIGNATURE	SHEET 15 OF 19			

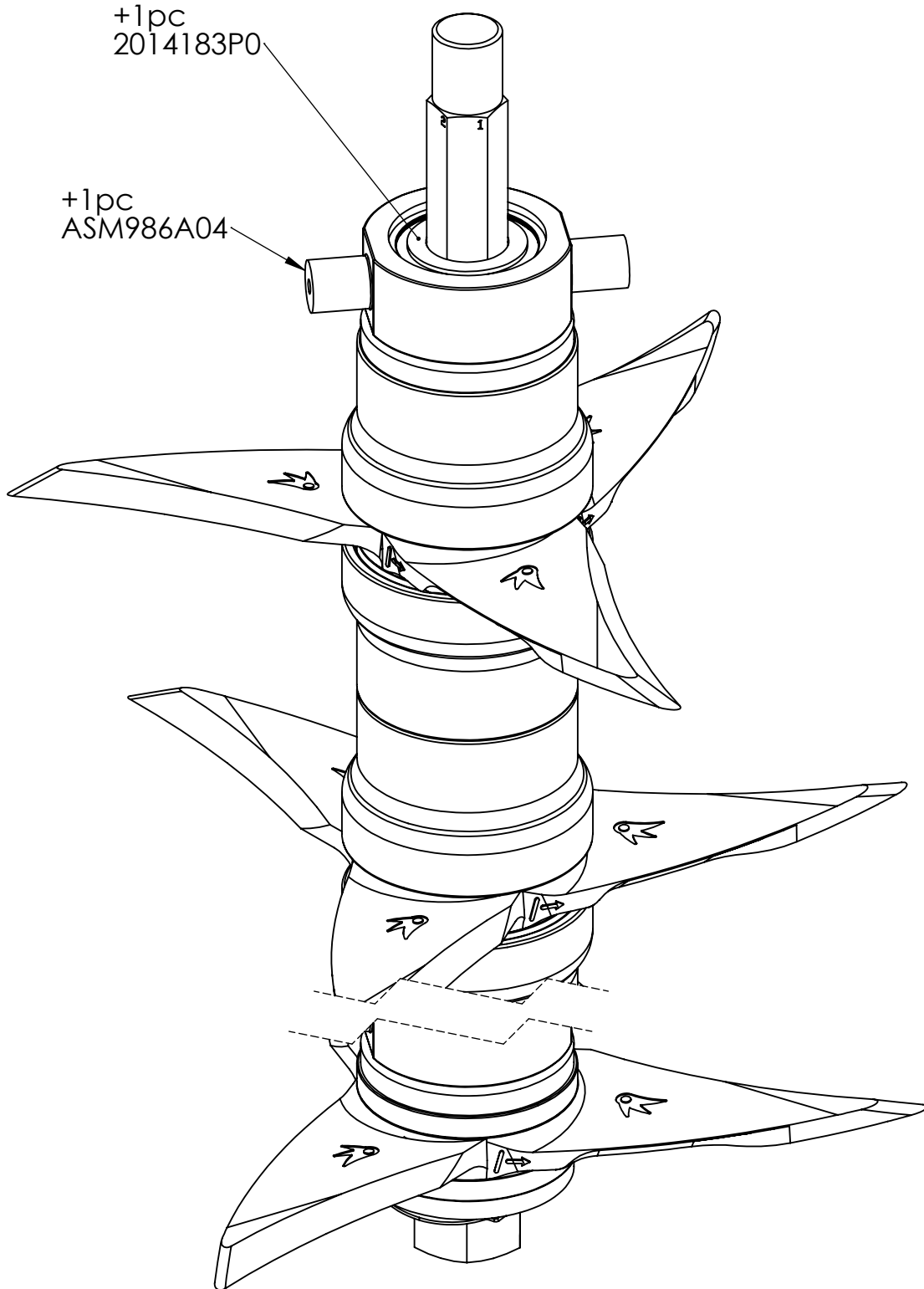

Assembly BOM Link: [ASM989A06.xls](#)
 (contains prints to constituent part prints)

Drawing Name: ASM989A06		REVISION 0 DATE 3/26/2016	PART NO. ASM989A06	DESCRIPTION: 6star Roller, CW
A:		DEBUR AND BREAK SHARP EDGES UNLESS OTHERWISE SPECIFIED: DIMENSIONS ARE IN INCHES SURFACE FINISH: TOLERANCES: LINEAR: 1/16" ANGULAR: 2°	PROCESSES	WEIGHT: 48.23Lbs
B:			Assemble	Soil Regeneration Unlimited
C:			Grease	
D:			DO NOT SCALE DRAWING	PROPRIETARY AND CONFIDENTIAL
E:			A4 SCALE: 1:2	THE INFORMATION CONTAINED IN THIS DRAWING IS THE SOLE PROPERTY OF SOIL REGENERATION UNLIMITED. ANY REPRODUCTION IN PART OR AS A WHOLE WITHOUT THE WRITTEN PERMISSION OF SOIL REGENERATION UNLIMITED IS PROHIBITED.
NAME Daniel R. M.	SIGNATURE	SHEET 16 OF 19		

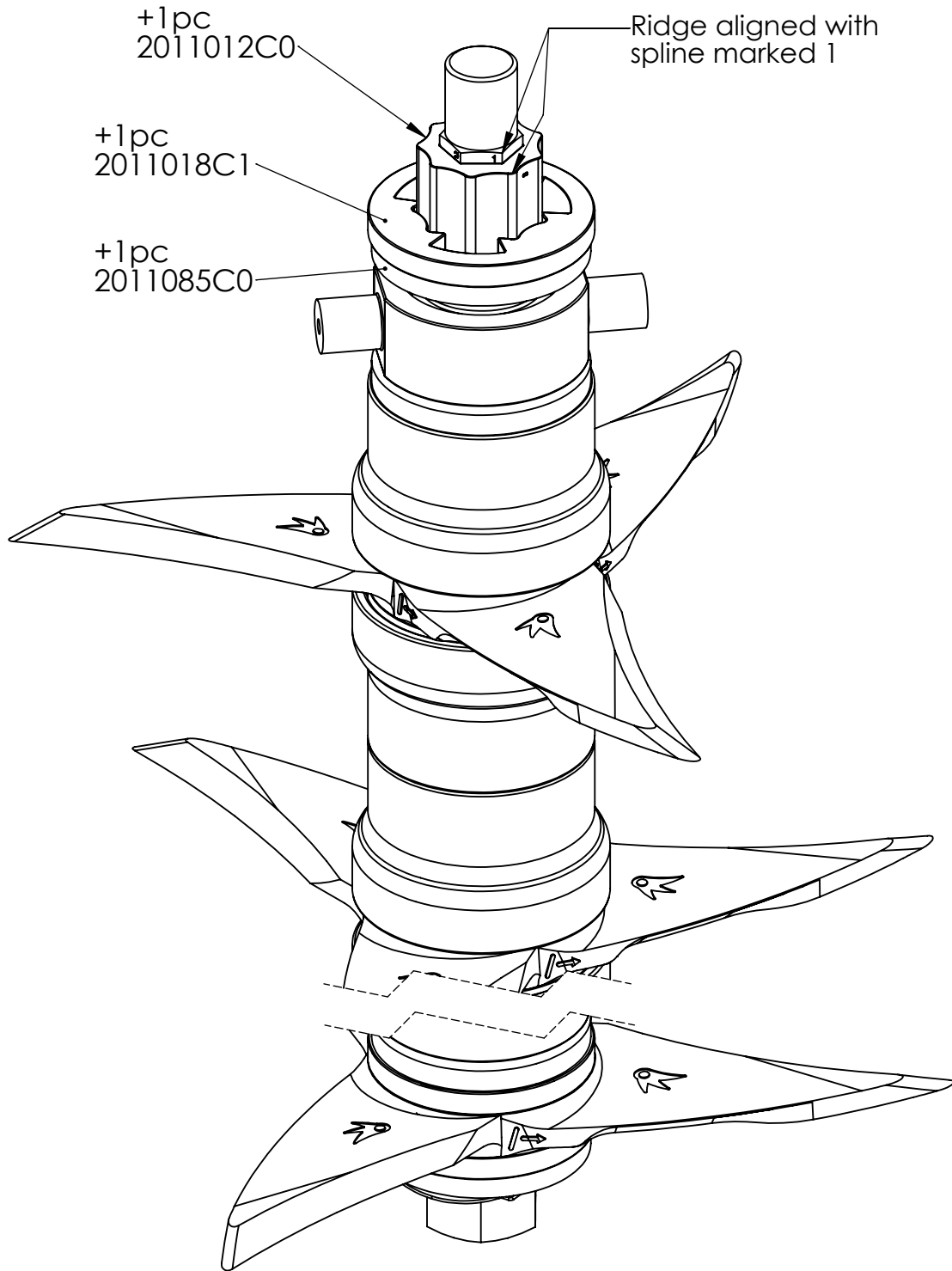

Assembly BOM Link: [ASM989A06.xls](#)
 (contains prints to constituent part prints)

Drawing Name: ASM989A06		REVISION 0 DATE 3/26/2016	PART NO. ASM989A06	DESCRIPTION: 6star Roller, CW
A:		DEBUR AND BREAK SHARP EDGES UNLESS OTHERWISE SPECIFIED: DIMENSIONS ARE IN INCHES SURFACE FINISH: TOLERANCES: LINEAR: 1/16" ANGULAR: 2°	PROCESSES	WEIGHT: 48.23Lbs
B:			Assemble	Soil Regeneration Unlimited
C:			Grease	
D:				PROPRIETARY AND CONFIDENTIAL
E:				THE INFORMATION CONTAINED IN THIS DRAWING IS THE SOLE PROPERTY OF SOIL REGENERATION UNLIMITED. ANY REPRODUCTION IN PART OR AS A WHOLE WITHOUT THE WRITTEN PERMISSION OF SOIL REGENERATION UNLIMITED IS PROHIBITED.
NAME Daniel R. M.	SIGNATURE	A4	SCALE: 1:2	SHEET 17 OF 19

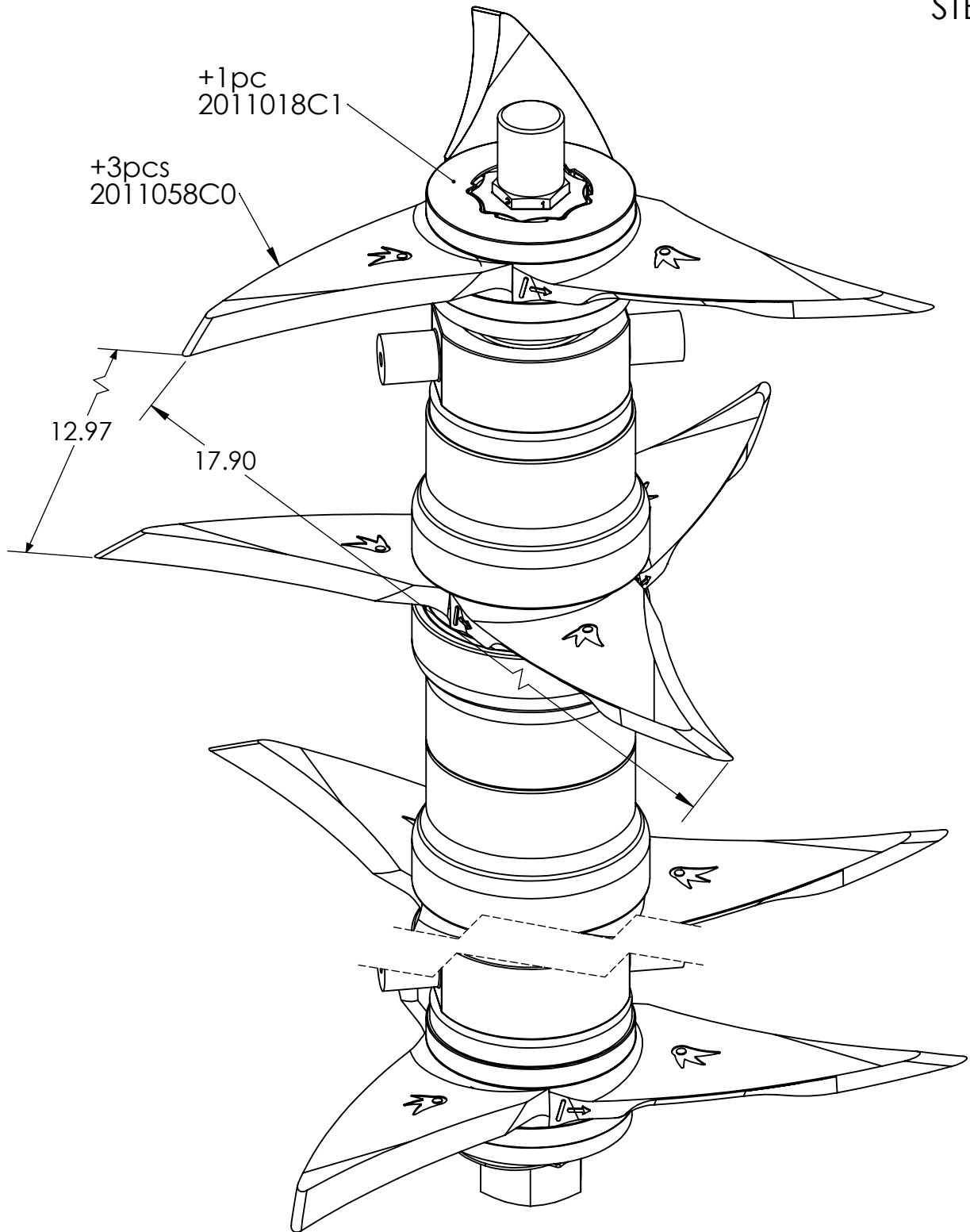

Assembly BOM Link: [ASM989A06.xls](#)
 (contains prints to constituent part prints)

Drawing Name: ASM989A06		REVISION 0 DATE 3/26/2016	PART NO. ASM989A06	DESCRIPTION: 6star Roller, CW
A:		DEBUR AND BREAK SHARP EDGES UNLESS OTHERWISE SPECIFIED: DIMENSIONS ARE IN INCHES SURFACE FINISH: TOLERANCES: LINEAR: 1/16" ANGULAR: 2°	PROCESSES	WEIGHT: 48.23Lbs
B:			Assemble	Soil Regeneration Unlimited
C:			Grease	
D:			DO NOT SCALE DRAWING	PROPRIETARY AND CONFIDENTIAL
E:			A4 SCALE: 1:2	THE INFORMATION CONTAINED IN THIS DRAWING IS THE SOLE PROPERTY OF SOIL REGENERATION UNLIMITED. ANY REPRODUCTION IN PART OR AS A WHOLE WITHOUT THE WRITTEN PERMISSION OF SOIL REGENERATION UNLIMITED IS PROHIBITED.
NAME Daniel R. M.	SIGNATURE	SHEET 18 OF 19		

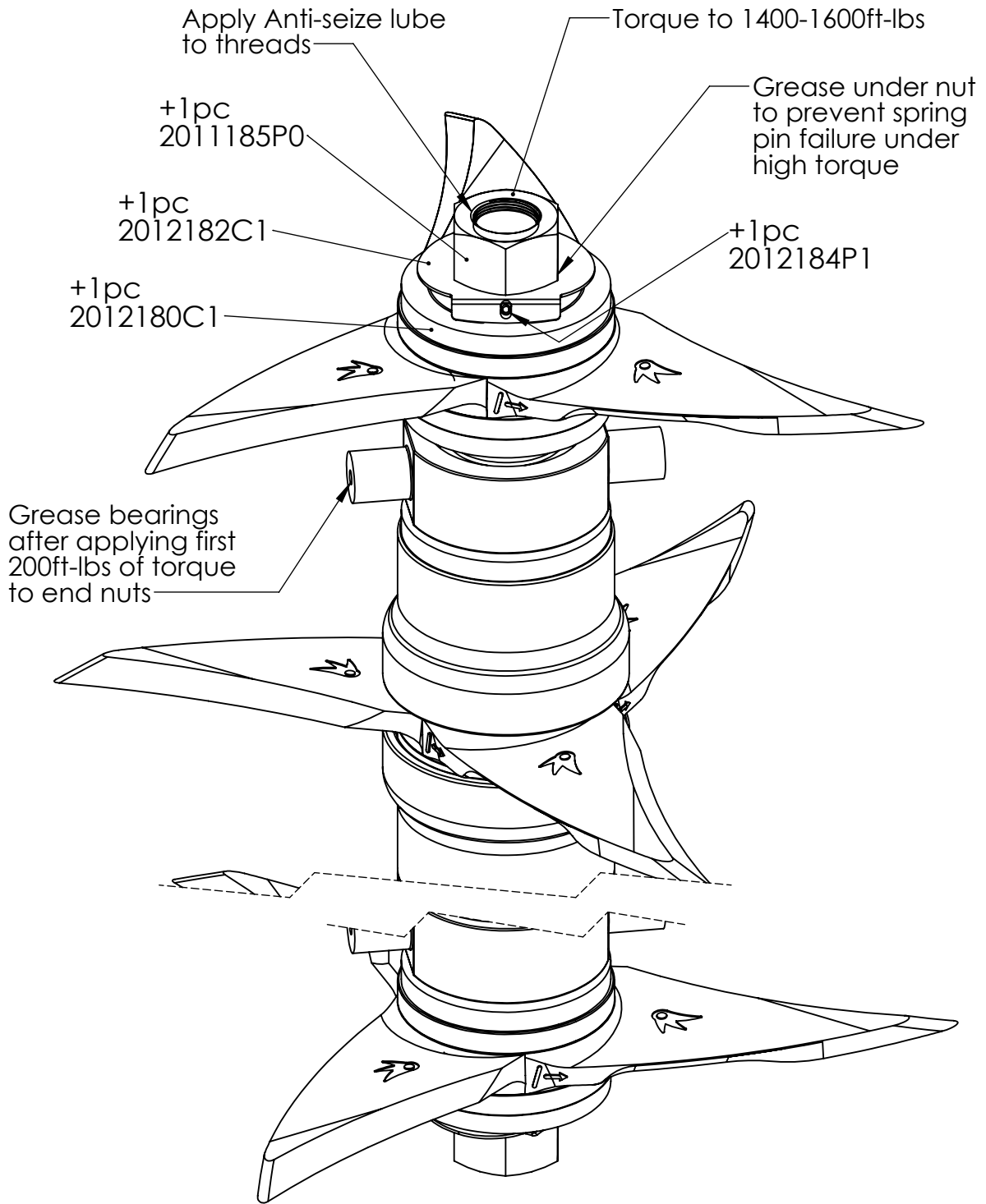

Assembly BOM Link: [ASM989A06.xls](#)
 (contains prints to constituent part prints)

Drawing Name: ASM989A06		REVISION 0 DATE 3/26/2016	PART NO. ASM989A06	DESCRIPTION: 6star Roller, CW
A:		DEBUR AND BREAK SHARP EDGES UNLESS OTHERWISE SPECIFIED: DIMENSIONS ARE IN INCHES SURFACE FINISH: TOLERANCES: LINEAR: 1/16" ANGULAR: 2°	PROCESSES	WEIGHT: 48.23Lbs
B:			Assemble	Soil Regeneration Unlimited
C:			Grease	
D:			DO NOT SCALE DRAWING	PROPRIETARY AND CONFIDENTIAL
E:			A4 SCALE: 1:2	THE INFORMATION CONTAINED IN THIS DRAWING IS THE SOLE PROPERTY OF SOIL REGENERATION UNLIMITED. ANY REPRODUCTION IN PART OR AS A WHOLE WITHOUT THE WRITTEN PERMISSION OF SOIL REGENERATION UNLIMITED IS PROHIBITED.
NAME Daniel R. M.	SIGNATURE	SHEET 19 OF 19		